

GATE 2024 Instrumentation Engineering Question Paper

Time Allowed :3 Hour	Maximum Marks :100	Total Questions :65
----------------------	--------------------	---------------------

General Instructions

Please read the following instructions carefully:

- This question paper is divided into three sections:
 - General Aptitude (GA):** 10 questions (5 questions \times 1 mark + 5 questions \times 2 marks) for a total of 15 marks.
 - Instrumentation Engineering:**
 - Part A (Mandatory):** 55 questions (25 questions \times 1 mark + 30 questions \times 2 marks) for a total of 85 marks.
- The total number of questions is **65**, carrying a maximum of **100 marks**.
- The duration of the exam is **3 hours**.
- Marking scheme:
 - For 1-mark MCQs, $\frac{1}{3}$ mark will be deducted for every incorrect response.
 - For 2-mark MCQs, $\frac{2}{3}$ mark will be deducted for every incorrect response.
 - No negative marking for numerical answer type (NAT) questions.
 - No marks will be awarded for unanswered questions.
- Ensure you attempt questions only from the optional section (Part B1 or Part B2) you have selected.
- Follow the instructions provided during the exam for submitting your answers.

General Aptitude GA

1. If '→' denotes increasing order of intensity, then the meaning of the words [drizzle → rain → downpour] is analogous to [_____ → quarrel → feud]. Which one of the given options is appropriate to fill the blank?

- (A) bicker
- (B) bog
- (C) dither
- (D) dodge

2. Statements:

- All heroes are winners.
- All winners are lucky people.

Inferences:

- I. All lucky people are heroes.
- II. Some lucky people are heroes.
- III. Some winners are heroes.

Which of the above inferences can be logically deduced from statements 1 and 2?

- (A) Only I and II
 - (B) Only II and III
 - (C) Only I and III
 - (D) Only III
-

3. A student was supposed to multiply a positive real number p with another positive real number q . Instead, the student divided p by q . If the percentage error in the student's answer is 80%, the value of q is:

- (A) 5
 - (B) $\sqrt{2}$
 - (C) 2
 - (D) $\sqrt{5}$
-

4. If the sum of the first 20 consecutive positive odd numbers is divided by 20^2 , the result is:

- (A) 1
 - (B) 20
 - (C) 2
 - (D) $\frac{1}{2}$
-

5. The ratio of the number of girls to boys in class VIII is the same as the ratio of the number of boys to girls in class IX. The total number of students (boys and girls) in classes VIII and IX is 450 and 360, respectively. If the number of girls in classes VIII and IX is the same, then the number of girls in each class is:

- (A) 150
 - (B) 200
 - (C) 250
 - (D) 175
-

6. In the given text, the blanks are numbered (i)–(iv). Select the best match for all the blanks.

Yoko Roi stands ---- (i) as an author for standing ---- (ii) as an honorary fellow, after she stood ---- (iii) her writings that stand ---- (iv) the freedom of speech.

- (A) (i) out (ii) down (iii) in (iv) for
- (B) (i) down (ii) out (iii) by (iv) in

- (C) (i) down (ii) out (iii) for (iv) in
 (D) (i) out (ii) down (iii) by (iv) for

7. Seven identical cylindrical chalk-sticks are fitted tightly in a cylindrical container. The figure below shows the arrangement of the chalk-sticks inside the cylinder.

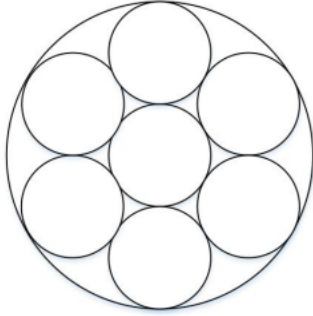

The length of the container is equal to the length of the chalk-sticks. The ratio of the occupied space to the empty space of the container is:

- (A) $\frac{5}{2}$
 (B) $\frac{7}{2}$
 (C) $\frac{9}{2}$
 (D) 3

Q.8 The plot below shows the relationship between the mortality risk of cardiovascular disease and the number of steps a person walks per day. Based on the data, which one of the following options is true?

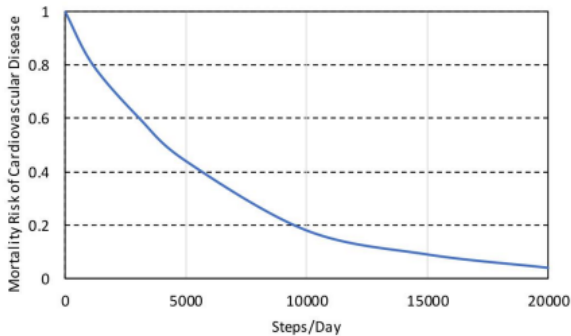

- (A) The risk reduction on increasing the steps/day from 0 to 10,000 is less than the risk reduction on increasing the steps/day from 10,000 to 20,000.
 (B) The risk reduction on increasing the steps/day from 0 to 5,000 is less than the risk reduction on increasing the steps/day from 15,000 to 20,000.
 (C) For any 5,000 increment in steps/day, the largest risk reduction occurs on going from 0 to 5,000.
 (D) For any 5,000 increment in steps/day, the largest risk reduction occurs on going from 15,000 to 20,000.

Q.9 Five cubes of identical size and another smaller cube are assembled as shown in Figure A. If viewed from direction X , the planar image of the assembly appears as Figure B.

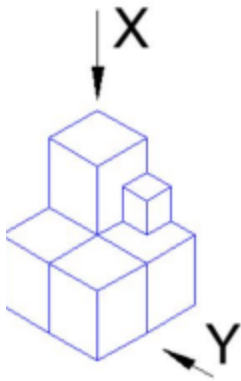
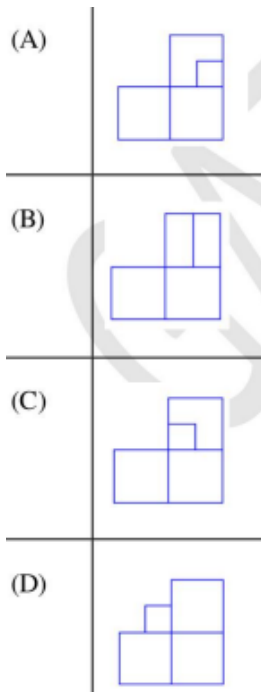

Figure A



Figure B

If viewed from direction Y , the planar image of the assembly (Figure A) will appear as:



10. Visualize a cube that is held with one of the four body diagonals aligned to the vertical axis. Rotate the cube about this axis such that its view remains unchanged. The magnitude of the minimum angle of rotation is:

- (A) 120°
- (B) 60°
- (C) 90°
- (D) 180°

11. Let $z = x + iy$ be a complex variable and \bar{z} be its complex conjugate. The equation $\bar{z}^2 + z^2 = 2$ represents a:

- (A) Parabola
- (B) Hyperbola

- (C) Ellipse
(D) Circle

12. The pressure drop across a control valve is constant. The control valve with inherent characteristic has decreasing sensitivity. If x represents the fraction of maximum stem position of the control valve, then the function $f(x)$ representing the fraction of maximum flow is:

- (A) αx^{-1} , where α is constant
(B) \sqrt{x}
(C) x
(D) x^2

13. A discrete-time sequence is given by $x[n] = [1, 2, 3, 4]$ for $0 \leq n \leq 3$. The zero-lag auto-correlation value of $x[n]$ is:

- (A) 1
(B) 10
(C) 20
(D) 30

14. Match the following measuring devices with their principle of measurement:

Measuring Device	Principle of Measurement
(P) Optical pyrometer	(I) Variation in mutual inductance
(Q) Thermocouple	(II) Change in resistance
(R) Strain gauge	(III) Wavelength of radiated energy
(S) Linear variable differential transformer	(IV) Electromotive force generated by two dissimilar metals

- (A) (P) – (III), (Q) – (IV), (R) – (II), (S) – (I)
(B) (P) – (IV), (Q) – (III), (R) – (II), (S) – (I)
(C) (P) – (III), (Q) – (I), (R) – (IV), (S) – (II)
(D) (P) – (II), (Q) – (IV), (R) – (I), (S) – (III)

15. The capacitor shown in the figure has parallel plates, with each plate having an area A . The thickness of the dielectric materials are d_1 and d_2 and their relative permittivities are ϵ_1 and ϵ_2 , respectively. Assume that the fringing field effects are negligible and ϵ_0 is the permittivity of free space.

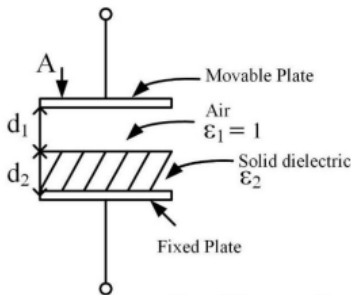

If d_1 is decreased by δd_1 , the resultant capacitance becomes:

- (A) $\frac{\epsilon_0 A}{d_1 - \delta d_1 + \frac{d_2}{\epsilon_2}}$

- (B) $\frac{\varepsilon_0 A}{d_2 + \frac{d_1}{\varepsilon_2}}$
 (C) $\frac{\varepsilon_0 A}{d_2 - \delta d_2 + \frac{d_1}{\varepsilon_2}}$
 (D) $\frac{\varepsilon_0 A}{d_1 + \delta d_1 + \frac{d_2}{\varepsilon_2}}$

16. Among the given options, the simplified form of the Boolean function $F = (A + \overline{A}B) + \overline{A}(A + \overline{B})C$ is:

- (A) $A + B + C$
 (B) $A \cdot B \cdot C$
 (C) $B + \overline{A} \cdot C$
 (D) $\overline{A} + B \cdot C$

17. Consider the state-space representation of a system

$$\dot{x} = Ax + Bu$$

where x is the state vector, u is the input, A is the system matrix, and B is the input matrix. Choose the matrix A from the following options such that the system has a pole at the origin.

- (A) $\begin{bmatrix} 0 & 1 \\ -2 & -3 \end{bmatrix}$
 (B) $\begin{bmatrix} 1 & -1.5 \\ -2 & 3 \end{bmatrix}$
 (C) $\begin{bmatrix} 1 & 1.5 \\ 2 & -3 \end{bmatrix}$
 (D) $\begin{bmatrix} 0 & 1 \\ -2 & 3 \end{bmatrix}$

18. The sinusoidal transfer function corresponding to the polar plot shown in the figure, for $T > 0$, is:

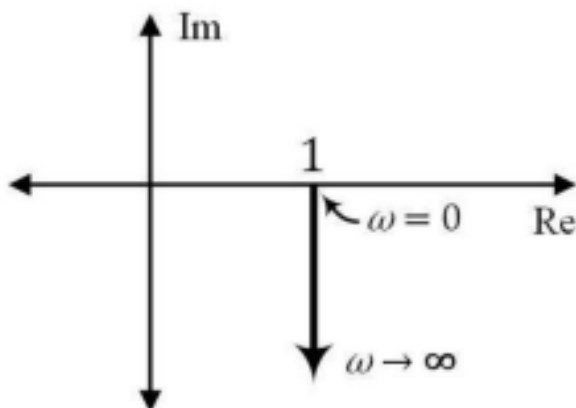

- (A) $1 - j\omega T$
 (B) $\frac{1 - j\omega T}{1 + j\omega T}$
 (C) $1 + j\omega T$
 (D) $\frac{1}{1 + j\omega T}$

19. A matrix M is constructed by stacking three column vectors v_1, v_2, v_3 as

$$M = [v_1 \ v_2 \ v_3].$$

Choose the set of vectors from the following options such that $\text{rank}(M) = 3$:

- (A) $v_1 = \begin{bmatrix} 1 \\ 0 \\ 1 \end{bmatrix}$, $v_2 = \begin{bmatrix} 0 \\ -1 \\ 0 \end{bmatrix}$, $v_3 = \begin{bmatrix} -1 \\ -1 \\ 1 \end{bmatrix}$
- (B) $v_1 = \begin{bmatrix} 1 \\ 1 \\ 1 \end{bmatrix}$, $v_2 = \begin{bmatrix} -1 \\ 0 \\ 1 \end{bmatrix}$, $v_3 = \begin{bmatrix} 0 \\ 0 \\ 0 \end{bmatrix}$
- (C) $v_1 = \begin{bmatrix} 1 \\ 0 \\ 1 \end{bmatrix}$, $v_2 = \begin{bmatrix} -1 \\ 0 \\ 1 \end{bmatrix}$, $v_3 = \begin{bmatrix} 1 \\ -1 \\ 1 \end{bmatrix}$
- (D) $v_1 = \begin{bmatrix} 1 \\ 1 \\ 1 \end{bmatrix}$, $v_2 = \begin{bmatrix} -1 \\ 1 \\ -1 \end{bmatrix}$, $v_3 = \begin{bmatrix} 0 \\ -1 \\ 0 \end{bmatrix}$
-

20. The capacitance formed between two concentric spherical metal shells having radii x and y with $y > x$ is given by:

Note: ϵ is the permittivity of the medium between the shells.

- (A) $4\pi\epsilon \left(\frac{xy}{y-x} \right)$
- (B) $4\pi\epsilon \left(\frac{x^2}{y-x} \right)$
- (C) $4\pi\epsilon \left(\frac{y^2}{y-x} \right)$
- (D) $4\pi\epsilon \left(\frac{y^2 - xy}{x} \right)$
-

21. A linear transducer is calibrated for the ranges shown in the figure. The gain of the transducer is _____ mA/°C (rounded off to two decimal places).

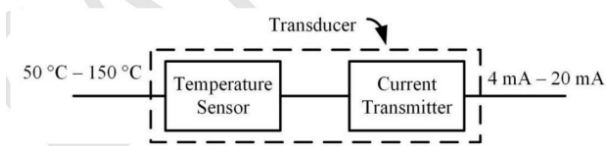

22. Consider a filter defined by the difference equation

$$y[n] - 0.5y[n-2] = ax[n-4],$$

where $x[n]$ and $y[n]$ represent the input and output, respectively. If the magnitude response of the filter at $\omega = \frac{\pi}{2}$ is $|H(\frac{\pi}{2})| = 0.5$, the value of a is _____ (rounded off to two decimal places).

23. Consider the circuit shown in the figure.

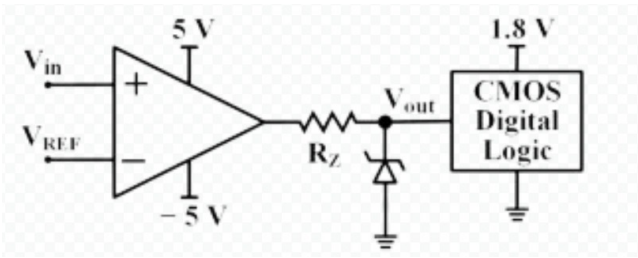

The CMOS digital logic circuit has infinite input impedance. Assume the opamp is ideal. A 1.8 V Zener diode with a minimum Zener current of 2 mA is used. The corresponding maximum value of resistance R_Z is _____ k Ω (rounded off to one decimal place).

24. Figure shows an amplifier using an NMOS transistor. Assume that the transistor is in saturation with device parameters, $\mu_n C_{ox} = 250 \mu A/V^2$, threshold voltage $V_T = 0.65 V$, and $W/L = 4$. Ignore the channel length modulation effect. The drain current of the transistor at the operating point is _____ μA (rounded off to the nearest integer).

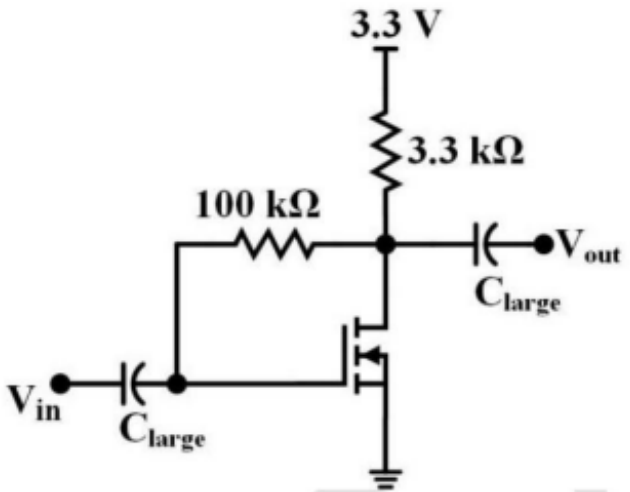

25. The number of complex multiplications required for computing a 16-point DFT using the decimation-in-time radix-2 FFT is _____ (in integer).

26. A 3×3 matrix P with all real elements has eigenvalues $\frac{1}{4}$, 1, and -2 . The value of $|P^{-1}|$ is _____ (rounded off to nearest integer).

27. The Nyquist sampling frequency for $x(t) = 10 \sin^2(200\pi t)$ is _____ Hz (rounded off to nearest integer).

28. The resistance of a 20 k Ω resistor is measured six consecutive times using an LCR meter. The first five readings are 19 k Ω , 18 k Ω , 23 k Ω , 21 k Ω , and 17 k Ω . If the mean of the measurements and the true value are equal, the last reading is _____ k Ω (rounded off to nearest integer).

29. Consider the readout circuit of a piezoelectric sensor shown in the figure.

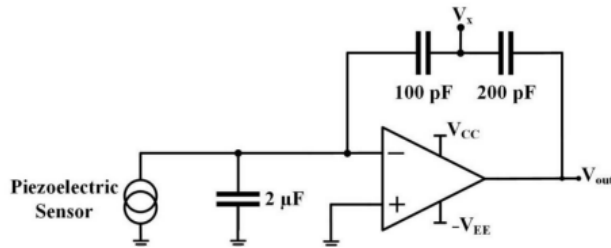

When the piezoelectric sensor generates a charge q_p , the resulting change in voltage V_x is -2 V . Then the corresponding change in the voltage V_{out} is _____ V (rounded off to nearest integer)

Note: Assume all components are ideal.

30. The voltage applied and the current drawn by a circuit are given as:

$$v(t) = 95 + 200 \cos(120\pi t) + 90 \cos(360\pi t - 60^\circ) \text{ V},$$

$$i(t) = 4 \cos(120\pi t - 60^\circ) + 1.5 \cos(240\pi t - 75^\circ) \text{ A}.$$

The average power absorbed by the circuit is _____ W (rounded off to nearest integer).

31. The current $i(t)$ drawn by a circuit is given as:

$$i(t) = 4 + 30 \cos(t) - 20 \sin(t) + 15 \cos(3t) - 10 \sin(3t) \text{ A}.$$

The root-mean-square (RMS) value of $i(t)$ is _____ A (rounded off to one decimal place).

32. A linear potentiometer ($0 - 10 \text{ k}\Omega$) is used to measure the water level as shown in the figure. The resistance between A and C varies linearly from 0 to $10 \text{ k}\Omega$ for a change in water level from 0 to 20 cm . The sensor is excited using a DC voltage source, $V_S = 10 \text{ V}$ with an internal resistance, $R_S = 200 \Omega$. If $V_{\text{out}} = 5 \text{ V}$, the water level is _____ cm (rounded off to one decimal place).

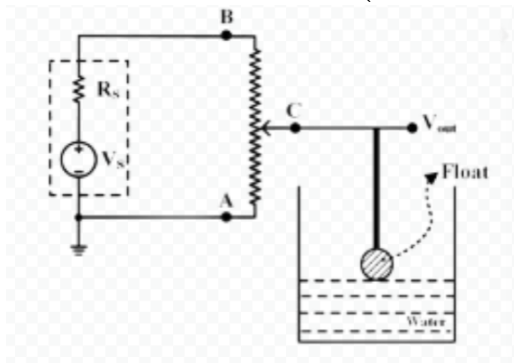

33. The switch in the following figure has been closed for a long time ($t < 0$). It is opened at $t = 0$ seconds. The value of $\frac{dv_c}{dt}$ at $t = 0^+$ is _____ V/s (rounded off to nearest integer).

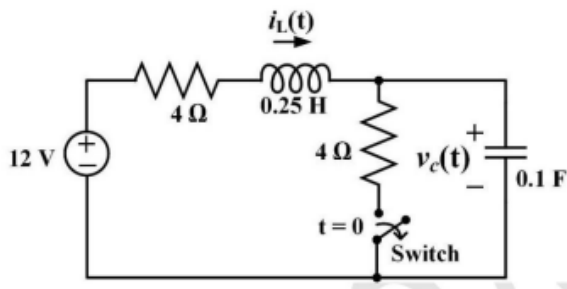

34. Consider a system given by the following first-order differential equation:

$$\frac{dy}{dt} = y + 2t - t^2$$

where, $y(0) = 1$ and $0 \leq t < \infty$. Using a step size $h = 0.1$ for the improved Euler method, the value of $y(t)$ at $t = 0.1$ is _____ (rounded off to two decimal places).

35. Indian Premier League has divided the sixteen cricket teams into two equal pools: Pool-A and Pool-B. Four teams of Pool-A have blue logo jerseys while the rest four have red logo jerseys. Five teams of Pool-B have blue logo jerseys while the rest three have red logo jerseys.

If one team from each pool reaches the final, the probability that one team has a blue logo jersey and another has a red logo jersey is _____ (rounded off to one decimal place).

36. A wire of circular cross section with radius a is shown in the figure. The current density is given by $J = ks^2$, where k is a constant, s is the radial distance from the axis, and $0 \leq s \leq a$. The total current I in the wire is:

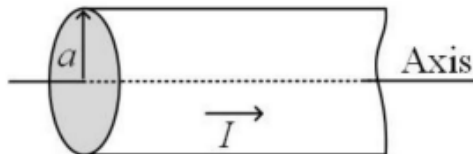

- (A) $\frac{\pi ka^4}{2}$
- (B) $\frac{2\pi ka^3}{3}$
- (C) $\frac{\pi ka^3}{2}$
- (D) $\frac{\pi ka^4}{4}$

37. The measured values from a flow instrument, whose range is between 0 and 2 flow units, are shown in the histogram. The systematic error (bias) and the maximum error (in flow units), respectively are:

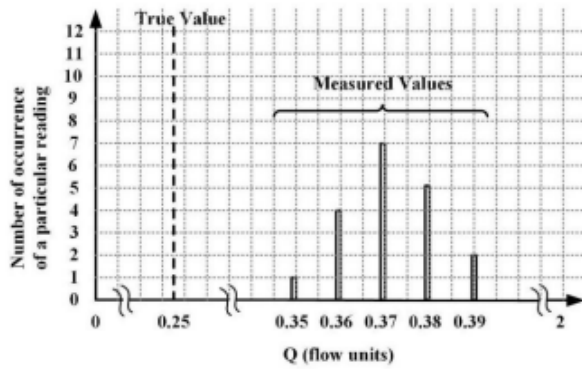

- (A) 0.12 and 0.14
 (B) 0.01 and 0.10
 (C) 0.10 and 0.14
 (D) 0.04 and 0.12

38. Consider a discrete-time sequence:

$$x[n] = \begin{cases} (0.2)^n, & 0 \leq n \leq 7 \\ 0, & \text{otherwise} \end{cases}$$

The region of convergence of $X(z)$, the z-transform of $x[n]$, consists of:

- (A) all values of z except $z = 0.2$
 (B) all values of z
 (C) all values of z except $z = 0$
 (D) all values of z except $z = \infty$

39. In the bridge circuit shown in the figure, under balanced condition, the values of R and C respectively, are:

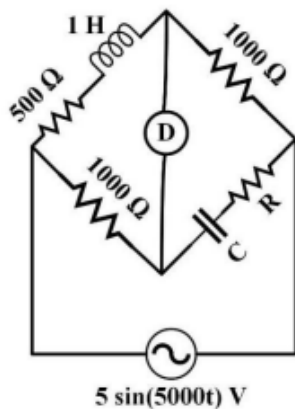

- (A) 1.010Ω and $19.802 \mu F$
 (B) 9.901Ω and $0.505 \mu F$
 (C) 19.802Ω and $1.01 \mu F$
 (D) 39.604Ω and $2.02 \mu F$

40. Laplace transform of a signal $x(t)$ is given as:

$$X(s) = \frac{1}{s^2 + 13s + 42}$$

Let $u(t)$ be the unit step function. Choose the signal $x(t)$ from the following options if the region of convergence is $-7 < \text{Re}\{s\} < -6$.

- (A) $-e^{-6t}u(t) - e^{-7t}u(-t)$
- (B) $-e^{-6t}u(-t) - e^{-7t}u(t)$
- (C) $e^{-6t}u(t) - e^{-7t}u(-t)$
- (D) $-e^{-6t}u(t) - e^{-7t}u(-t)$

41. In the figure shown, both the opamps A_1 and A_2 are ideal, except that the opamp A_1 has an offset voltage (V_{OS}) of 1 mV. For $V_{in} = 0$ V, the values of the output voltages V_{out1} and V_{out2} , respectively, are:

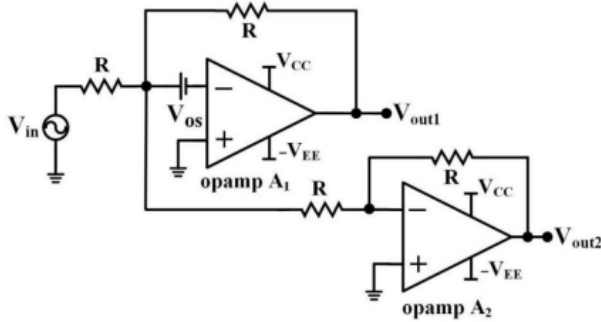

- (A) 3 mV and -1 mV
- (B) 1 mV and 0 mV
- (C) 1 mV and -1 mV
- (D) 2 mV and 0 mV

42. In the figure shown, the positive edge-triggered D flip-flops are initially reset to $Q = 0$. The logic gates and the multiplexers have no propagation delay. After reset, a train of clock pulses (CLK) are applied. The logic states of the inputs DIN, S, and the clock pulses are also shown in the figure. Assuming no timing violations, the sequence of output Y from the 3rd clock to the 5th clock, $Y_3Y_4Y_5$, is:

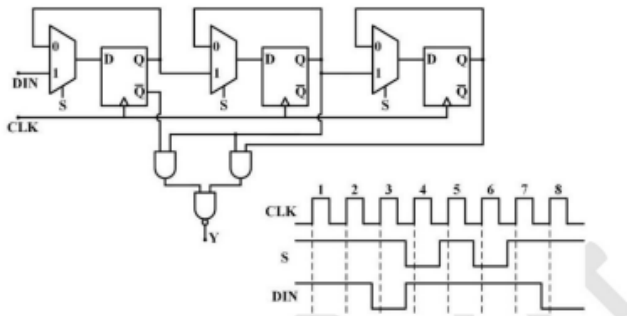

- (A) 001
- (B) 010
- (C) 000
- (D) 011

43. In the figure shown, $R = 1 \text{ k}\Omega$ and $C = 0.1 \mu\text{F}$. For a DC gain of -10 , the 3 dB cut-off frequency (rounded off to one decimal place) is: Assume the opamp is ideal.

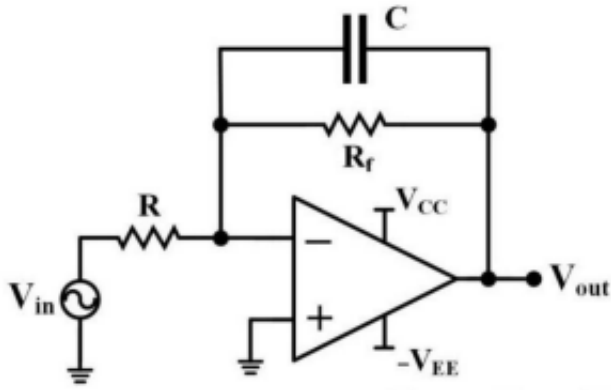

- (A) 159.1 Hz
- (B) 1591.5 Hz
- (C) 1750.7 Hz
- (D) 175.0 Hz

44. Consider the feedback control system shown in the figure. The steady-state error $e_{ss} = \lim_{t \rightarrow \infty} (r(t) - y(t))$ due to a unit step reference $r(t)$ is:

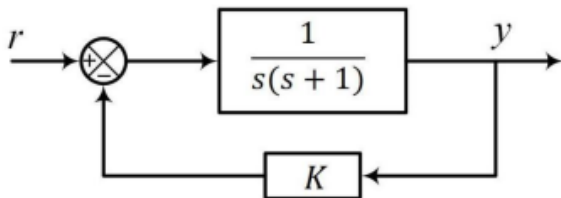

- (A) $\frac{K-1}{K}$
- (B) $\frac{1}{2}$
- (C) 0
- (D) $\frac{1-K}{K}$

45. The transfer function of a system is given as:

$$G(s) = \frac{\omega_n^2}{s^2 + 2\xi\omega_n s + \omega_n^2}$$

Choose the range of ξ and ω_n (in rad/s) from the following options such that the poles lie on the shaded region of the s -plane as shown in the figure.

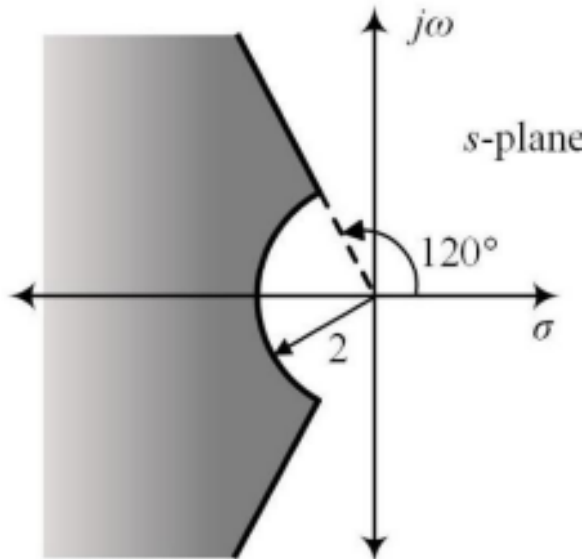

- (A) $\xi \geq \frac{1}{2}$ and $\omega_n \geq 2$
 (B) $\xi \geq \frac{1}{4}$ and $\omega_n \geq 2$
 (C) $\xi \geq \frac{1}{2}$ and $\omega_n \geq \sqrt{3}$
 (D) $\xi \geq \frac{1}{4}$ and $\omega_n \geq \sqrt{3}$

46. Let C be the closed curve in the xy -plane, traversed in the counterclockwise direction along the boundary of the rectangle with vertices at $(0, 0)$, $(2, 0)$, $(2, 1)$, $(0, 1)$. The value of the line integral:

$$\oint_C (-e^y dx + e^x dy)$$

is:

- (A) $e^2 + 2e - 3$
 (B) $e^2 - 2e - 3$
 (C) $e^2 + e - 1$
 (D) $e^2 + e + 1$

47. In the figure shown, assume:

- α is the phase angle between the load current and the load voltage.
- β is the phase angle by which the pressure coil current lags the pressure coil voltage of the wattmeter.
- γ is the phase angle between currents in the pressure coil and the current coil of the wattmeter.
- δ is the phase angle of the voltage transformer.
- θ is the phase angle of the current transformer.

When the load has a lagging phase angle of α , which one of the following options is correct?

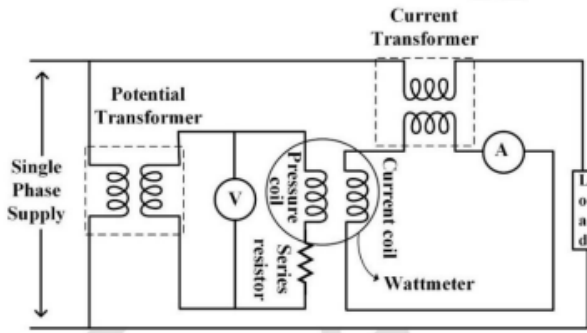

- (A) $\alpha = -\gamma \pm \delta \pm \theta - \beta$
 (B) $\alpha = -\gamma \pm \delta \pm \theta + \beta$
 (C) $\alpha = \gamma \pm \delta \pm \theta + \beta$
 (D) $\alpha = \gamma \pm \delta \pm \theta - \beta$

48. Consider an ultrasonic measurement system shown in the figure. The ultrasonic transmitter (T) sends a continuous wave signal $x(t) = \cos(2\pi f_1 t)$ volts towards an object whose vibration is modeled as $m(t) = 0.5 \sin(2\pi f_2 t)$ volts.

Neglecting the phase shift due to any other effect, the received signal at the receiver (R) is $y(t) = \cos(2\pi f_1 t + \beta \cos(2\pi f_2 t))$ volts.

Assuming the frequency sensitivity factor as 500 Hz/volt, $f_1 = 40$ kHz, $f_2 = 1$ kHz, the modulation index (β) and the frequency deviation in $y(t)$, respectively, are:

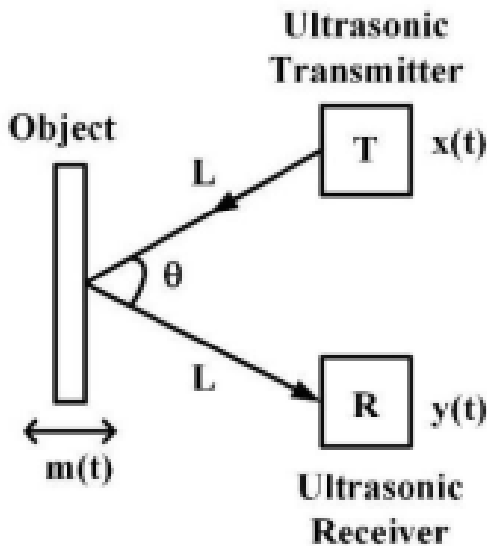

- (A) 0.25 and ± 250 Hz
 (B) 0.5 and ± 500 Hz
 (C) 1 and ± 1000 Hz
 (D) 0.75 and ± 1000 Hz

49. The complex functions $f(z) = u(x, y) + iv(x, y)$ and $\overline{f(z)} = u(x, y) - iv(x, y)$ are both analytic in a given domain. Choose the correct option(s) from the following.

- (A) $\frac{\partial u}{\partial x} = \frac{\partial v}{\partial y} = 0$
 (B) $\frac{\partial u}{\partial y} = -\frac{\partial v}{\partial x} \neq 0$

- (C) $\frac{df(z)}{dz} = 0$
 (D) $\frac{df(z)}{dz} \neq 0$

50. The readings recorded from a 20-psig pressure gauge are given in the Table. The regression line obtained for the data is $y = 0.04x + 10.32$. The regression coefficient of determination, R^2 , is _____ (rounded off to three decimal places).

x	1	2	3	4	5
y (psig)	10.3	10.5	10.4	10.5	10.5

Q.51 In the figure shown, $R = 4.5 \text{ k}\Omega$, $\Delta R = 1.5 \text{ k}\Omega$, and the Instrumentation Amplifier (INA) is assumed to be ideal. The equivalent resistance between points A and B is _____ $\text{k}\Omega$ (rounded off to the nearest integer).

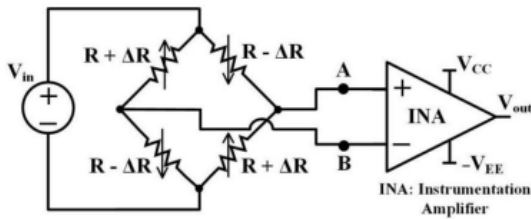

52. Consider the capacitive sensor circuit and its output voltage shown in the figure. The circuit is switched ON at $t = 0$. Assuming the opamp to be ideal, the frequency of the output voltage V_o is _____ kHz (rounded off to two decimal places).

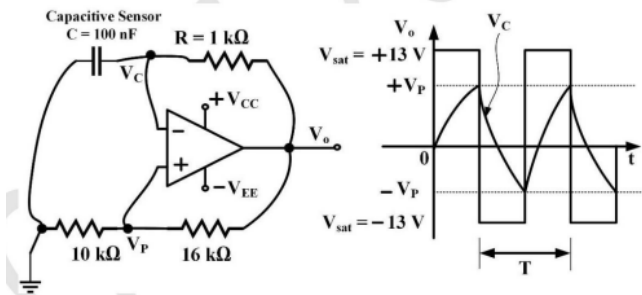

53. The 4-point DFTs of two sequences $x[n]$ and $y[n]$ are $X[k] = [1, -j, 1, j]$ and $Y[k] = [1, 3j, 1, -3j]$, respectively. Assuming $z[n]$ represents the 4-point circular convolution of $x[n]$ and $y[n]$, the value of $z[0]$ is _____ (rounded off to nearest integer).

Note: The DFT of a N -point sequence $x[n]$ is defined as:

$$X[k] = \sum_{n=0}^{N-1} x[n] e^{-j2\pi nk/N}$$

Q.54 Consider the figure shown. For zero deflection in the galvanometer, the required value of resistor R_x is _____ Ω (rounded off to the nearest integer).

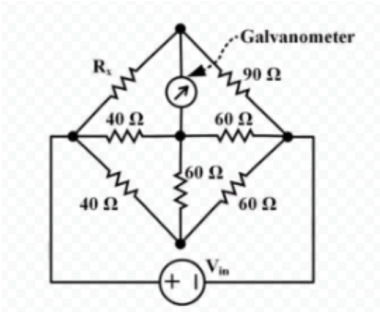

55. Consider a unity negative feedback system with its open-loop pole-zero map as shown in the figure. If the point $s = j\alpha$, $\alpha > 0$, lies on the root locus, the value of α is _____ (rounded off to nearest integer).

Note: The poles are marked with \times in the figure.

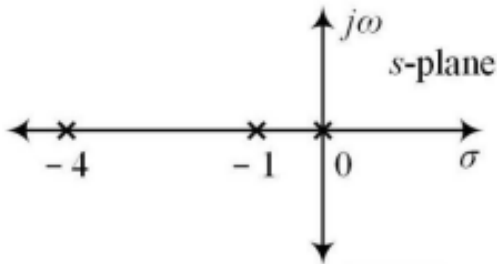

56. A shielded cable with $C_{\text{stray}} = 20 \text{ pF}$ and $R_{\text{wire}} = 10 \text{ } \Omega$ is used to connect the inductive sensors as shown in the figure. The RMS value of V_{out} is ___ V (rounded off to two decimal places).

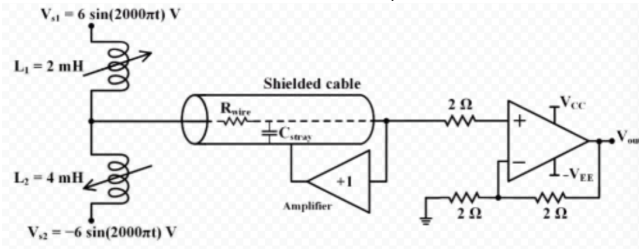

Note: Assume all components are ideal, and sensors are not magnetically coupled.

57. In the figure shown, the diode current is given by $I_D = I_S e^{\frac{\alpha V_D}{T}}$, where V_D is the diode voltage in volts, T is the absolute temperature in Kelvin, $\alpha = 1.16 \times 10^4 \text{ K/V}$, and $I_S = 10^{-15} \text{ A}$ is the saturation current. The DC current source, op-amp, and the resistors are ideal, and are assumed to be temperature independent. The change in the output voltage (V_{out}) per Kelvin change in temperature is ____ mV (rounded off to one decimal place).

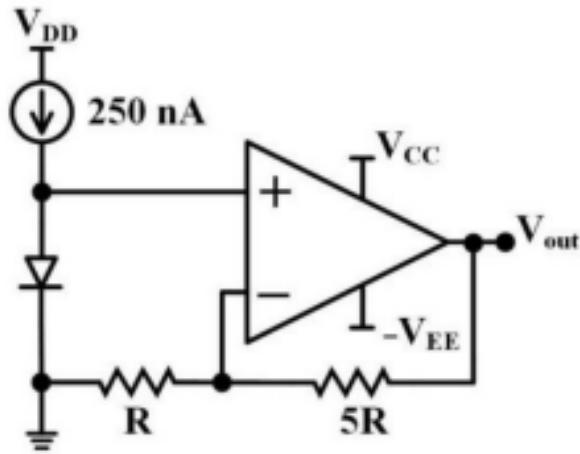

58. An ADC has a full-scale voltage of 1.4 V, resolution of 200 mV, and produces binary output data. The input signal of the ADC has a bandwidth of 500 MHz, and it samples the data at the Nyquist rate. The parallel data output is converted to a serial bit stream using a parallel-to-serial converter. The data rate at the output of the parallel-to-serial converter is ____ Gbps (rounded off to nearest integer).

59. In the circuit shown, assume the opamp is ideal and the initial charge on the capacitor is zero. The output voltage at time $t = 2$ ms is ____ V (rounded off to one decimal place).

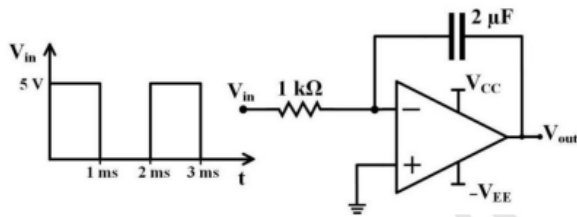

60. In the figure shown, S_w is a switch whose position changes from 1 to 0 when V_C changes from logic HIGH to LOW and vice versa. The bandwidth of the permanent magnet moving coil (PMMC) type voltmeter is 1 Hz. If $V_{\text{sense}} = 2 \sin(4000\pi t)$ V and $V_{\text{ref}} = 4 \sin(2000\pi t)$ V, the voltmeter reading is ____ V (rounded off to nearest integer).

Note : Assume all components are ideal.

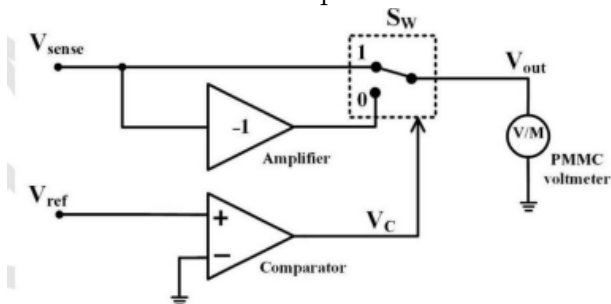

61. A 50 kVA transformer has an efficiency of 95% at full load and unity power

factor. Assume the core losses are negligible. The efficiency of the transformer at 75% of the full load and 0.8 power factor is _____ (rounded off to one decimal place).

62. A three-phase squirrel-cage induction motor has a starting torque of 100% of the full load torque and a maximum torque of 300% of the full load torque. Neglecting the stator impedance, the slip at the maximum torque is _____ (rounded off to two decimal places).

Q.63 Two magnetically coupled coils, when connected in series-aiding configuration, have a total inductance of 500 mH. When connected in series-opposing configuration, the coils have a total inductance of 300 mH. If the self-inductance of both the coils are equal, then the coupling coefficient is _____ (rounded off to two decimal places).

Q.64 The solution of an ordinary differential equation $y''' + 3y'' + 3y' + y = 30e^{-t}$ is:

$$y(t) = (c_0 + c_1t - c_2t^2 + c_3t^3) e^{-t}.$$

Given $y(0) = 3$, $y'(0) = -3$, and $y''(0) = -47$, the value of $c_0 + c_1 + c_2 + c_3$ is _____ (rounded off to nearest integer).

Note: $y''' = \frac{d^3y}{dt^3}$, $y'' = \frac{d^2y}{dt^2}$, $y' = \frac{dy}{dt}$ and c_0, c_1, c_2, c_3 are constants.

Q.65 A random variable X has a probability density function:

$$f_X(x) = \begin{cases} e^{-x}, & x \geq 0, \\ 0, & \text{otherwise.} \end{cases}$$

The probability of $X > 2$ is _____ (rounded off to three decimal places).