

NTA JEE Mains Apr 2026 Paper I

Section : Mathematics Section A

Q.1 The square of the distance of the point of intersection of the lines $\vec{r} = (\hat{i} + \hat{j} - \hat{k}) + \lambda(\hat{a}\hat{i} - \hat{j})$, $a \neq 0$ and $\vec{r} = (4\hat{i} - \hat{k}) + \mu(2\hat{i} + a\hat{k})$ from the origin is:

- Options
1. 17
 2. 10
 3. 5
 4. 26

Question Type : **MCQ**

Question ID : **695278315**

Option 1 ID : **6952781079**

Option 2 ID : **6952781078**

Option 3 ID : **6952781077**

Option 4 ID : **6952781080**

Status : **Answered**

Chosen Option : **2**

Q.2 In an equilateral triangle PQR, let the vertex P be at (3, 5) and the side QR be along the line $x + y = 4$. If the orthocentre of the triangle PQR is (α, β) , then $9(\alpha + \beta)$ is equal to:

- Options
1. 27
 2. 16
 3. 48
 4. 36

Question Type : **MCQ**

Question ID : **695278311**

Option 1 ID : **6952781062**

Option 2 ID : **6952781061**

Option 3 ID : **6952781064**

Option 4 ID : **6952781063**

Status : **Answered**

Chosen Option : **4**

Q.3 Let the sum of the first n terms of an A.P. be $3n^2 + 5n$. Then the sum of squares of the first 10 terms of the A.P. is:

- Options
1. 10220
 2. 19780
 3. 15220
 4. 12860

Question Type : **MCQ**

Question ID : **695278302**

Option 1 ID : **6952781025**

Option 2 ID : **6952781028**

Option 3 ID : **6952781027**

Option 4 ID : **6952781026**

Status : **Answered**

Chosen Option : **1**

Q.4 A letter is known to have arrived by post either from KANPUR or from ANANTPUR. On the envelope just two consecutive letters AN are visible. The probability, that the letter came from ANANTPUR, is:

- Options
1. $\frac{12}{19}$
 2. $\frac{7}{19}$
 3. $\frac{10}{17}$
 4. $\frac{7}{10}$

Question Type : **MCQ**

Question ID : **695278307**

Option 1 ID : **6952781047**

Option 2 ID : **6952781048**

Option 3 ID : **6952781046**

Option 4 ID : **6952781045**

Status : **Answered**

Chosen Option : **2**

Q.5

Let $\tan A, \tan B$, where $A, B \in \left(-\frac{\pi}{2}, \frac{\pi}{2}\right)$, be the roots of the quadratic equation $x^2 - 2x - 5 = 0$. Then $20 \sin^2\left(\frac{A+B}{2}\right)$ is equal to:

- Options
1. $10 + \sqrt{10}$
 2. $10 - 3\sqrt{10}$
 3. $10 - \sqrt{10}$
 4. $10 - 2\sqrt{10}$

Question Type : **MCQ**Question ID : **695278306**Option 1 ID : **6952781041**Option 2 ID : **6952781043**Option 3 ID : **6952781044**Option 4 ID : **6952781042**Status : **Answered**Chosen Option : **2**

Q.6

Consider the system of linear equations in x, y, z :

$$x + 2y + tz = 0,$$

$$6x + y + 5tz = 0,$$

$$3x + t^2y + f(t)z = 0,$$

where $f: \mathbb{R} \rightarrow \mathbb{R}$ is a differentiable function. If this system has infinitely many solutions for all $t \in \mathbb{R}$, then f

- Options
1. is a constant function
 2. has two critical points
 3. is strictly increasing on \mathbb{R}
 4. is strictly decreasing on \mathbb{R}

Question Type : **MCQ**Question ID : **695278304**Option 1 ID : **6952781033**Option 2 ID : **6952781036**Option 3 ID : **6952781034**Option 4 ID : **6952781035**Status : **Answered**Chosen Option : **2**

Q.7

The value of the integral $\int_{\frac{\pi}{6}}^{\frac{\pi}{3}} \left(\frac{4 - \operatorname{cosec}^2 x}{\cos^4 x} \right) dx$ is:

Options

1. $\frac{11}{\sqrt{3}}$
2. $\frac{64}{3\sqrt{3}}$
3. $\frac{32}{3\sqrt{3}}$
4. $\frac{16}{\sqrt{3}}$

Question Type : MCQ

Question ID : 695278320

Option 1 ID : 6952781097

Option 2 ID : 6952781100

Option 3 ID : 6952781099

Option 4 ID : 6952781098

Status : Answered

Chosen Option : 2

Q.8

Let $f: \mathbb{R} \rightarrow \mathbb{R}$ be a differentiable function such that $f\left(\frac{x+y}{3}\right) = \frac{f(x)+f(y)}{3}$

for all $x, y \in \mathbb{R}$, and $f'(0) = 3$. Then the minimum value of the function $g(x) = 3 + e^x f(x)$, is:

Options

1. $3e$
2. $\frac{3-e}{e}$
3. $3\left(\frac{e+1}{e}\right)$
4. $3\left(\frac{e-1}{e}\right)$

Question Type : MCQ

Question ID : 695278319

Option 1 ID : 6952781096

Option 2 ID : 6952781095

Option 3 ID : 6952781093

Option 4 ID : 6952781094

Status : Answered

Chosen Option : 3

Q.9 The sum of all the integral values of p such that the equation $3\sin^2 x + 12\cos x - 3 = p$, $x \in \mathbb{R}$, has at least one solution, is:

- Options
1. -75
 2. -54
 3. -60
 4. -84

Question Type : **MCQ**

Question ID : **695278312**

Option 1 ID : **6952781067**

Option 2 ID : **6952781065**

Option 3 ID : **6952781066**

Option 4 ID : **6952781068**

Status : **Answered**

Chosen Option : **2**

Q.10 Let A be a 3×3 matrix such that

$$A^T \begin{bmatrix} 1 \\ 0 \\ 1 \end{bmatrix} = \begin{bmatrix} 5 \\ 2 \\ 2 \end{bmatrix}, A^T \begin{bmatrix} 0 \\ 0 \\ 1 \end{bmatrix} = \begin{bmatrix} 3 \\ 1 \\ 1 \end{bmatrix}, A \begin{bmatrix} 1 \\ 0 \\ 1 \end{bmatrix} = \begin{bmatrix} 3 \\ 4 \\ 4 \end{bmatrix} \text{ and } A \begin{bmatrix} 0 \\ 0 \\ 1 \end{bmatrix} = \begin{bmatrix} 1 \\ 3 \\ 1 \end{bmatrix}.$$

If $\det(A) = 1$, then $\det(\text{adj}(A^2 + A))$ is equal to:

- Options
1. 25
 2. 16
 3. 64
 4. 49

Question Type : **MCQ**

Question ID : **695278303**

Option 1 ID : **6952781030**

Option 2 ID : **6952781029**

Option 3 ID : **6952781032**

Option 4 ID : **6952781031**

Status : **Answered**

Chosen Option : **2**

Q.11 $\sum_{n=1}^{10} \left(\frac{528}{n(n+1)(n+2)} \right)$ is equal to:

- Options
1. 220
 2. 130
 3. 440
 4. 65

Question Type : **MCQ**

Question ID : **695278305**

Option 1 ID : **6952781039**

Option 2 ID : **6952781038**

Option 3 ID : **6952781040**

Option 4 ID : **6952781037**

Status : **Answered**

Chosen Option : **1**

Q.12 Let P be a moving point on the circle $x^2 + y^2 - 6x - 8y + 21 = 0$. Then, the maximum distance of P from the vertex of the parabola $x^2 + 6x + y + 13 = 0$ is equal to:

- Options
1. 9
 2. 10
 3. 12
 4. 8

Question Type : **MCQ**

Question ID : **695278310**

Option 1 ID : **6952781060**

Option 2 ID : **6952781058**

Option 3 ID : **6952781059**

Option 4 ID : **6952781057**

Status : **Answered**

Chosen Option : **2**

Q.13

Let a focus of the ellipse $E : \frac{x^2}{a^2} + \frac{y^2}{b^2} = 1$ be $S(4, 0)$ and its eccentricity be $\frac{4}{5}$. If the point $P(3, \alpha)$ lies on E and O is the origin, then the area of ΔPOS is equal to:

- Options
1. $\frac{24}{5}$
 2. $\frac{48}{5}$
 3. $\frac{12}{5}$
 4. $\frac{14}{5}$

Question Type : MCQ

Question ID : 695278309

Option 1 ID : 6952781055

Option 2 ID : 6952781056

Option 3 ID : 6952781053

Option 4 ID : 6952781054

Status : Answered

Chosen Option : 2

Q.14 The mean deviation about the mean for the data

x_i	5	7	9	10	12	15
f_i	8	6	2	2	2	6

is equal to:

- Options
1. $\frac{44}{13}$
 2. $\frac{46}{13}$
 3. $\frac{42}{13}$
 4. $\frac{40}{13}$

Question Type : MCQ

Question ID : 695278308

Option 1 ID : 6952781051

Option 2 ID : 6952781052

Option 3 ID : 6952781050

Option 4 ID : 6952781049

Status : Answered

Chosen Option : 1

Q.15 Let $\vec{a} = \sqrt{7}\hat{i} + \hat{j} - \hat{k}$ and $\vec{b} = \hat{j} + 2\hat{k}$. If \vec{r} is a vector such that $\vec{r} \times \vec{a} + \vec{a} \times \vec{b} = \vec{0}$ and $\vec{r} \cdot \vec{a} = 0$, then $|3\vec{r}|^2$ is equal to:

- Options
1. 86
 2. 132
 3. 54
 4. 44

Question Type : MCQ

Question ID : 695278314

Option 1 ID : 6952781075

Option 2 ID : 6952781076

Option 3 ID : 6952781074

Option 4 ID : 6952781073

Status : Answered

Chosen Option : 2

Q.16 The product of all possible values of α , for which

$$\lim_{x \rightarrow 0} \frac{1 - \cos(\alpha x) \cos((\alpha + 1)x) \cos((\alpha + 2)x)}{\sin^2((\alpha + 1)x)} = 2, \text{ is:}$$

- Options
1. $\frac{5}{4}$
 2. -2
 3. -1
 4. 1

Question Type : MCQ

Question ID : 695278317

Option 1 ID : 6952781088

Option 2 ID : 6952781085

Option 3 ID : 6952781087

Option 4 ID : 6952781086

Status : Answered

Chosen Option : 2

Q.17 The area of the region $R = \{(x, y): xy \leq 27, 1 \leq y \leq x^2\}$ is equal to:

- Options
1. $78 \log_e 3 - \frac{52}{3}$
 2. $54 \log_e 3 - \frac{26}{3}$
 3. $54 \log_e 3 - \frac{52}{3}$
 4. $54 \log_e 3 + \frac{26}{3}$

Question Type : **MCQ**

Question ID : **695278316**

Option 1 ID : **6952781081**

Option 2 ID : **6952781083**

Option 3 ID : **6952781082**

Option 4 ID : **6952781084**

Status : **Answered**

Chosen Option : **2**

Q.18 The value of the integral $\int_0^{\infty} \frac{\log_e(x)}{x^2+4} dx$ is:

- Options
1. $\frac{\pi \log_e(2)}{4}$
 2. $2 + \pi \log_e(2)$
 3. $1 + \pi \log_e(2)$
 4. $\frac{\pi \log_e(2)}{2}$

Question Type : **MCQ**

Question ID : **695278318**

Option 1 ID : **6952781090**

Option 2 ID : **6952781092**

Option 3 ID : **6952781091**

Option 4 ID : **6952781089**

Status : **Answered**

Chosen Option : **2**

Q.19 Let $a, b \in \mathbb{C}$. Let α, β be the roots of the equation $x^2 + ax + b = 0$. If $\beta - \alpha = \sqrt{11}$ and $\beta^2 - \alpha^2 = 3i\sqrt{11}$, then $(\beta^3 - \alpha^3)^2$ is equal to:

- Options
1. 160
 2. 176
 3. 194
 4. 187

Question Type : **MCQ**

Question ID : **695278301**

Option 1 ID : **6952781021**

Option 2 ID : **6952781022**

Option 3 ID : **6952781023**

Option 4 ID : **6952781024**

Status : **Answered**

Chosen Option : **2**

Q.20 The square of the distance of the point $P(5, 6, 7)$ from the line $\frac{x-2}{2} = \frac{y-5}{3} = \frac{z-2}{4}$ is equal to:

- Options
1. 3
 2. 6
 3. 8
 4. 5

Question Type : **MCQ**

Question ID : **695278313**

Option 1 ID : **6952781069**

Option 2 ID : **6952781071**

Option 3 ID : **6952781072**

Option 4 ID : **6952781070**

Status : **Answered**

Chosen Option : **2**

Section : Mathematics Section B

Q.21 Two players A and B play a series of games of badminton. The player, who wins 5 games first, wins the series. Assuming that no game ends in a draw, the number of ways, in which player A wins the series is _____.

Given --
Answer :

Question Type : **SA**

Question ID : **695278322**

Status : **Not Answered**

Q.22 If the sum of the coefficients of x^7 and x^{14} in the expansion of $\left(\frac{1}{x^3} - x^4\right)^n$, $x \neq 0$, is zero, then the value of n is _____.

Given --
Answer :

Question Type : SA
Question ID : 695278323
Status : Not Answered

Q.23 Let $A = \{1, 2, 3, 4, 5, 6\}$. The number of one-one functions $f: A \rightarrow A$ such that $f(1) \geq 3$, $f(3) \leq 4$ and $f(2) + f(3) = 5$, is _____.

Given --
Answer :

Question Type : SA
Question ID : 695278321
Status : Not Answered

Q.24 If $\frac{\pi}{4} + \sum_{p=1}^{11} \tan^{-1}\left(\frac{2^{p-1}}{1+2^{2p-1}}\right) = \alpha$, then $\tan \alpha$ is equal to _____.

Given --
Answer :

Question Type : SA
Question ID : 695278324
Status : Not Answered

Q.25 Let $y = y(x)$ be the solution of the differential equation $x \sin\left(\frac{y}{x}\right) dy = \left(y \sin\left(\frac{y}{x}\right) - x\right) dx$, $y(1) = \frac{\pi}{2}$ and let $\alpha = \cos\left(\frac{y(e^{12})}{e^{12}}\right)$. Then the number of integral value of p , for which the equation $x^2 + y^2 - 2px + 2py + \alpha + 2 = 0$ represents a circle of radius $r \leq 6$, is _____.

Given --
Answer :

Question Type : SA
Question ID : 695278325
Status : Not Answered

Section : Physics Section A

Q.26 Three masses $m_1 = 4$ kg, $m_2 = 4$ kg and $m_3 = 6$ kg are suspended from a fixed smooth frictionless pulley as shown in the figure below. The value of T_1/T_2 is

(take $g = 10 \text{ m/s}^2$)

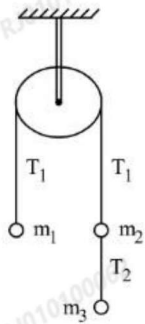

- Options**
1. $2/5$
 2. $5/3$
 3. $2/3$
 4. $3/5$

Question Type : **MCQ**

Question ID : **695278329**

Option 1 ID : **6952781121**

Option 2 ID : **6952781118**

Option 3 ID : **6952781119**

Option 4 ID : **6952781120**

Status : **Answered**

Chosen Option : **2**

Q.27 Two wires as shown in the figure below, made of steel and have breaking stress of $12 \times 10^8 \text{ N/m}^2$. Area of cross-section of upper wire is 0.008 cm^2 and of lower wire is 0.004 cm^2 . The maximum mass that can be added to pan without breaking any wire is _____ kg.

(take $g = 10 \text{ m/s}^2$)

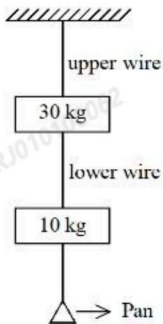

- Options**
1. 56
 2. 96
 3. 5.6
 4. 38

Question Type : **MCQ**

Question ID : **695278343**

Option 1 ID : **6952781174**

Option 2 ID : **6952781176**

Option 3 ID : **6952781177**

Option 4 ID : **6952781175**

Status : **Answered**

Chosen Option : **1**

Q.28 When one moves from a point 16 km below the earth's surface to a point 16 km above the earth's surface. The change in g is approximately α %. The value of α is _____.

(Take radius of the earth = 6400 km.)

- Options**
1. 0.75
 2. 0.50
 3. 0.12
 4. 0.25

Question Type : **MCQ**

Question ID : **695278328**

Option 1 ID : **6952781117**

Option 2 ID : **6952781116**

Option 3 ID : **6952781114**

Option 4 ID : **6952781115**

Status : **Answered**

Chosen Option : **2**

Q.29 Given below are two statements: one is labelled as **Assertion A** and the other is labelled as **Reason R**

Statement I: Change in internal energy of a system containing n mole of ideal

gas can be written as $\Delta U = n C_v (T_f - T_i) = \frac{nR}{\gamma - 1} (T_f - T_i)$, where

$\gamma = \frac{C_p}{C_v}$, T_i = initial temperature, T_f = final temperature.

Statement II: Relation between degree of freedom f and $\gamma (= C_p/C_v)$ is

$$\left(\gamma = 1 + \frac{2}{f} \right)$$

Choose the **correct** answer from the options given below

- Options
1. **A** is true but **R** is false
 2. Both **A** and **R** are true and **R** is the correct explanation of **A**
 3. **A** is false but **R** is true
 4. Both **A** and **R** are true but **R** is **NOT** the correct explanation of **A**

Question Type : **MCQ**

Question ID : **695278332**

Option 1 ID : **6952781132**

Option 2 ID : **6952781130**

Option 3 ID : **6952781133**

Option 4 ID : **6952781131**

Status : **Answered**

Chosen Option : **2**

Q.30 Consider the following statements:

- A. Zeroth law of thermodynamics gives concept of temperature
- B. First law of thermodynamics gives concept of internal energy
- C. In isothermal expansion of ideal gas, $\Delta Q \neq \Delta W$
- D. Product of intensive and extensive variables is extensive
- E. The ratio of any extensive variable to mass will be an extensive variable

Choose the correct combination of statements from the options given below:

- Options**
1. A, B and C Only
 2. B, C and D Only
 3. A, B and D Only
 4. C, D and E Only

Question Type : **MCQ**

Question ID : **695278333**

Option 1 ID : **6952781135**

Option 2 ID : **6952781137**

Option 3 ID : **6952781136**

Option 4 ID : **6952781134**

Status : **Answered**

Chosen Option : **1**

Q.31 The Young's modulus of steel wire of radius r and length L is Y .

If the radius r and length L of the wire are doubled then the value of Y

- Options**
1. remains unchanged
 2. increases by two times
 3. becomes one fourth
 4. reduces by half

Question Type : **MCQ**

Question ID : **695278331**

Option 1 ID : **6952781128**

Option 2 ID : **6952781126**

Option 3 ID : **6952781129**

Option 4 ID : **6952781127**

Status : **Answered**

Chosen Option : **4**

Q.32 In the hydrogen atom, the electron makes a transition from the higher orbit (i) to a lower orbit (f). The ratio of the radius of the orbits is given by $r_i : r_f = 16 : 4$. The wavelength of photon emitted due to this transition is _____ nm.
(Given Rydberg constant = $1.0973 \times 10^7 / \text{m}$)

- Options
1. 242
 2. 486
 3. 974
 4. 121

Question Type : **MCQ**

Question ID : **695278336**

Option 1 ID : **6952781147**

Option 2 ID : **6952781148**

Option 3 ID : **6952781149**

Option 4 ID : **6952781146**

Status : **Answered**

Chosen Option : **4**

Q.33 In a Vernier calipers, when both jaws touch each other, zero of the Vernier scale is shifted to the right of zero of the main scale and 7th Vernier division coincides with a main scale reading. If the value of 1 main scale division is 1 mm and there are 10 Vernier scale divisions, then the Vernier caliper has

- Options
1. 0.07 cm negative zero error
 2. 0.7 cm negative zero error
 3. 0.7 cm positive zero error
 4. 0.07 cm positive zero error

Question Type : **MCQ**

Question ID : **695278326**

Option 1 ID : **6952781106**

Option 2 ID : **6952781107**

Option 3 ID : **6952781109**

Option 4 ID : **6952781108**

Status : **Answered**

Chosen Option : **4**

Q.34 Light source having wavelength 331 nm is used to generate photo-electrons whose stopping potential is 0.2 V. The work function of the used metal in the experiment is $a \times 10^{-19}$ J. The value of a is _____.
($h = 6.62 \times 10^{-34}$ J s, $e = 1.6 \times 10^{-19}$ C and $c = 3 \times 10^8$ m/s)

- Options**
1. 4.68
 2. 2.68
 3. 5.68
 4. 3.68

Question Type : **MCQ**

Question ID : **695278341**

Option 1 ID : **6952781167**

Option 2 ID : **6952781169**

Option 3 ID : **6952781168**

Option 4 ID : **6952781166**

Status : **Answered**

Chosen Option : **2**

Q.35 A wedge Y with mass of 10 kg and all frictionless surfaces and the inclined surface making 37° with horizontal. A block X with mass 2 kg is placed at the highest point of the wedge as shown in figure is at rest. At $t = 0$ wedge (Y) is pulled toward right with constant force (f) of 24 N. Taking the block X at rest at $t = 0$, the time taken by it to slide down 8.8 m on the slope, while Y is on the move, is ____ s.
(take $\tan(37^\circ) = 3/4$ and $g = 10 \text{ m/s}^2$)

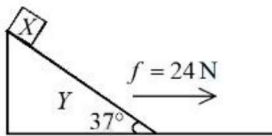

- Options**
1. 2
 2. 4
 3. $2\sqrt{2}$
 4. $\sqrt{2}$

Question Type : **MCQ**

Question ID : **695278330**

Option 1 ID : **6952781122**

Option 2 ID : **6952781123**

Option 3 ID : **6952781125**

Option 4 ID : **6952781124**

Status : **Answered**

Chosen Option : **4**

Q.36 In Young's double slit experiment, the fringe width of the interference pattern produced on the screen is $2.4 \mu\text{m}$. If the experiment is carried out in another medium having refractive index 1.2, the fringe width will be ____ μm .

- Options
1. 2
 2. 2.88
 3. 2.4
 4. 1.2

Question Type : **MCQ**

Question ID : **695278339**

Option 1 ID : **6952781159**

Option 2 ID : **6952781161**

Option 3 ID : **6952781160**

Option 4 ID : **6952781158**

Status : **Answered**

Chosen Option : **1**

Q.37 An a.c. source of angular frequency ω is connected across a resistor R and a capacitor C in series. The current is observed as I . Now the frequency of the source is changed to $\omega/4$, (keeping the voltage unchanged) the current is found to be $I/3$. The ratio of resistance to reactance at frequency ω is

- Options
1. $\sqrt{\frac{6}{7}}$
 2. $\sqrt{\frac{7}{8}}$
 3. $\sqrt{\frac{3}{5}}$
 4. $\sqrt{\frac{3}{4}}$

Question Type : **MCQ**

Question ID : **695278344**

Option 1 ID : **6952781178**

Option 2 ID : **6952781180**

Option 3 ID : **6952781179**

Option 4 ID : **6952781181**

Status : **Answered**

Chosen Option : **3**

Q.38 Refer to the figure given below. The values of I_1 , I_2 and I_3 are _____.

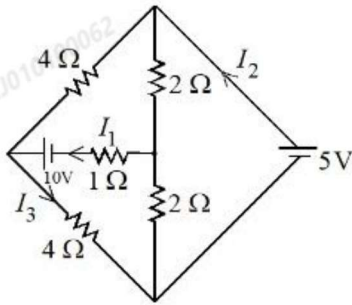

- Options
1. $I_1 = 1.875 \text{ A}$, $I_2 = 1.875 \text{ A}$, $I_3 = 2.5 \text{ A}$
 2. $I_1 = 2.5 \text{ A}$, $I_2 = 1.875 \text{ A}$, $I_3 = 1.875 \text{ A}$
 3. $I_1 = 1.875 \text{ A}$, $I_2 = 2.5 \text{ A}$, $I_3 = 1.875 \text{ A}$
 4. $I_1 = 2.5 \text{ A}$, $I_2 = 2.5 \text{ A}$, $I_3 = 1.875 \text{ A}$

Question Type : **MCQ**

Question ID : **695278334**

Option 1 ID : **6952781140**

Option 2 ID : **6952781138**

Option 3 ID : **6952781139**

Option 4 ID : **6952781141**

Status : **Answered**

Chosen Option : **2**

Q.39 Refer to the figure given below, current between terminals A and B is

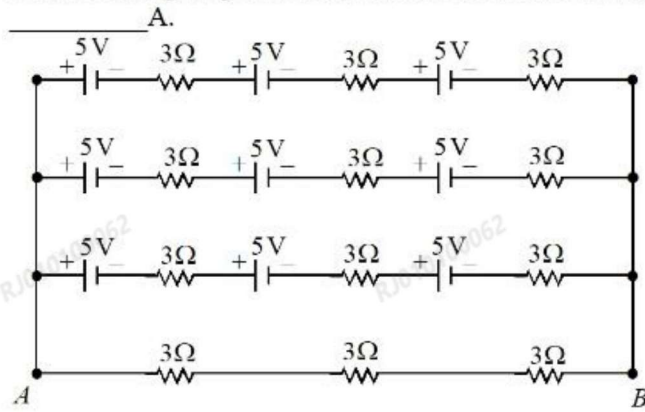

Options 1. 1.25

2. 12.5

3. 5

4. 7.5

Question Type : **MCQ**

Question ID : **695278338**

Option 1 ID : **6952781155**

Option 2 ID : **6952781154**

Option 3 ID : **6952781157**

Option 4 ID : **6952781156**

Status : **Answered**

Chosen Option : 1

Q.40 For the given logic circuit, which of the following inputs combination will make both LED-1 and LED-2 to glow?

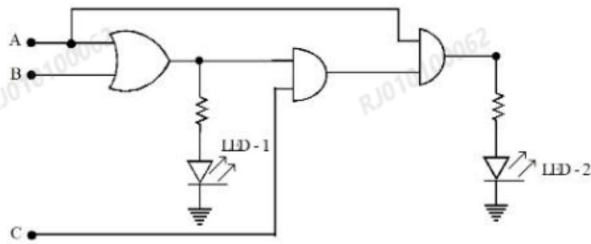

- Options**
1. A = 1, B = 1, C = 0
 2. A = 0, B = 1, C = 1
 3. A = 1, B = 0, C = 1
 4. A = 1, B = 0, C = 0

Question Type : **MCQ**

Question ID : **695278345**

Option 1 ID : **6952781185**

Option 2 ID : **6952781182**

Option 3 ID : **6952781184**

Option 4 ID : **6952781183**

Status : **Answered**

Chosen Option : **3**

Q.41 A compound microscope is designed with two symmetric biconvex lenses. The objective lens is cut vertically, creating two identical plano-convex lenses. One of them is used in place of original objective lens. To retain same magnification keeping the object distance unchanged, the tube length has to be

- Options**
1. increased two times
 2. increased $\frac{3}{2}$ times
 3. decreased two times
 4. decreased $\frac{3}{2}$ times

Question Type : **MCQ**

Question ID : **695278342**

Option 1 ID : **6952781170**

Option 2 ID : **6952781171**

Option 3 ID : **6952781172**

Option 4 ID : **6952781173**

Status : **Answered**

Chosen Option : **4**

Q.42 An electron of mass m is moving in an electric field $\vec{E} = -2E_0\hat{i}$ ($E_0 = \text{constant} > 0$), with an initial velocity $\vec{v} = v_0\hat{i}$ ($v_0 = \text{constant} > 0$). If $\lambda_0 = \frac{h}{4mv_0}$, its de Broglie wavelength at time t is

($e = \text{charge of electron}$)

Options

1. $\frac{4\lambda_0}{1 - \frac{2E_0 e t}{m v_0}}$

2. $\frac{4\lambda_0}{1 + \frac{2E_0 e t}{m v_0}}$

3. $\frac{4\lambda_0}{1 - \frac{E_0 e t}{2m v_0}}$

4. $\frac{4\lambda_0}{1 + \frac{E_0 e t}{2m v_0}}$

Question Type : MCQ

Question ID : 695278335

Option 1 ID : 6952781145

Option 2 ID : 6952781144

Option 3 ID : 6952781142

Option 4 ID : 6952781143

Status : Answered

Chosen Option : 3

Q.43 L , C and R represents physical quantities inductance, capacitance and resistance respectively. The dimensional formula $M L^2 T^{-4} A^{-2}$ corresponds to _____.

Options

1. $\frac{R}{LC}$

2. $\frac{C}{\sqrt{LR}}$

3. $\frac{R}{\sqrt{LC}}$

4. $\frac{1}{R} \sqrt{\frac{L}{C}}$

Question Type : **MCQ**

Question ID : **695278327**

Option 1 ID : **6952781111**

Option 2 ID : **6952781112**

Option 3 ID : **6952781110**

Option 4 ID : **6952781113**

Status : **Answered**

Chosen Option : **4**

Q.44 A ray of light passing through an equilateral prism is having velocity 2.12×10^8 m/s in the prism material, then the minimum angle of deviation is _____ degrees.

Options 1. 28

2. 58

3. 30

4. 45

Question Type : **MCQ**

Question ID : **695278340**

Option 1 ID : **6952781164**

Option 2 ID : **6952781165**

Option 3 ID : **6952781163**

Option 4 ID : **6952781162**

Status : **Answered**

Chosen Option : **4**

Q.45 A displacement current of 4.0 A can be set up in the space between two parallel plates of 6 μF capacitor. The rate of change of potential difference across the plates of the capacitor is nearly $\alpha \times 10^6$ V/s. The value of α is _____.

- Options
1. 0.58
 2. 0.67
 3. 0.82
 4. 0.75

Question Type : **MCQ**

Question ID : **695278337**

Option 1 ID : **6952781150**

Option 2 ID : **6952781151**

Option 3 ID : **6952781152**

Option 4 ID : **6952781153**

Status : **Answered**

Chosen Option : **2**

Section : **Physics Section B**

Q.46 The charged particle moving in a uniform magnetic field of $(3\hat{i} + 2\hat{j})\text{T}$ has an acceleration $\left(4\hat{i} - \frac{x}{2}\hat{j}\right)\text{m/s}^2$. The value of x is

Given --
Answer :

Question Type : **SA**

Question ID : **695278349**

Status : **Not Answered**

Q.47 From 18 m height above the ground a ball is dropped from rest . The height above the ground at which the magnitude of velocity equal to the magnitude of acceleration (in the same set of units) due to gravity is ____ m.
(Take $g = 10 \text{ m/s}^2$ and neglect the air resistance)

Given --
Answer :

Question Type : **SA**

Question ID : **695278347**

Status : **Not Answered**

- Q.48** A transverse wave on a string is described by $y = 3\sin(36t + 0.018x + \pi/4)$, where x, y are in cm and t in seconds. The least distance between the two successive crests in the wave is ____ cm. (Nearest integer)

$$(\pi = 3.14)$$

Given --
Answer :

Question Type : SA
Question ID : 695278348
Status : Not Answered

- Q.49** In the given circuit below inductance values of L_1, L_2 and L_3 are same. The magnetic energy stored in the entire circuit is (U_t) and that stored in the L_2 inductor is (U_l). U_l / U_t is _____.
(Ignore the mutual inductance if any)

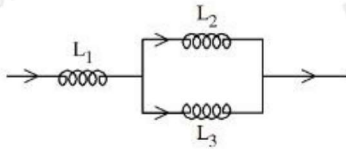

Given --
Answer :

Question Type : SA
Question ID : 695278350
Status : Not Answered

- Q.50** A cube has side length 5 cm and modulus of rigidity 10^5 N/m^2 . The displacement produced by a force of 10 N in the upper face of cube is ____ mm.

Given --
Answer :

Question Type : SA
Question ID : 695278346
Status : Not Answered

Section : Chemistry Section A

Q.51 The correct statements about metal carbonyls are

- A. The metal-carbon bonds in metal carbonyls possess both σ and π -character.
- B. Due to synergic bonding interactions between metal and CO ligand, the metal-carbon bond becomes weak.
- C. The metal-carbon σ bond is formed by the donation of lone pair of electrons on the carbonyl carbon into a vacant orbital of metal.
- D. The metal-carbon π bond is formed by the donation of electrons from filled d-orbital of metal into vacant π^* orbital of CO.

Choose the correct answer from the options given below:

- Options
- 1. A and B Only
 - 2. A, C and D Only
 - 3. A and D Only
 - 4. B and C Only

Question Type : **MCQ**

Question ID : **695278361**

Option 1 ID : **6952781231**

Option 2 ID : **6952781232**

Option 3 ID : **6952781234**

Option 4 ID : **6952781233**

Status : **Answered**

Chosen Option : **2**

Q.52 Consider compounds A, B and C with following structural formulae
 A = $\text{CH}_3 - \text{CH}_2 - \text{CH}_2 - \text{CH}_2 - \text{CH}_2 - \text{OH}$
 B = $\text{CH}_2 = \text{CH} - \text{CH}_2 - \text{CH}_2 - \text{CH}_3$
 C = $\text{HO} - \text{CH}_2 - \text{CH}_2 - \text{CH}(\text{OH}) - \text{CH}_3$
 For the conversion of B from A, reagent (D) required is _____ and structural formula of product (E) obtained when C undergoes same reaction using excess reagent (D) is _____.

Options

	D	E
1.	PCC	$\text{HO} - \text{CH}_2 - \text{CH}_2 - \text{CH} = \text{CH}_2$

	D	E
2.	Conc. H_2SO_4 or H_3PO_4	$\text{CH}_2 = \text{CH} - \text{CH} = \text{CH}_2$

	D	E
3.	PCC	$\text{CH}_2 = \text{CH} - \text{CH} = \text{CH}_2$

	D	E
4.	Conc. H_2SO_4	$\text{CH}_2 = \text{CH} - \text{CH}(\text{OH})\text{CH}_3$

Question Type : **MCQ**Question ID : **695278367**Option 1 ID : **6952781256**Option 2 ID : **6952781258**Option 3 ID : **6952781257**Option 4 ID : **6952781255**Status : **Answered**Chosen Option : **2**

Q.53 How many grams of residue is obtained by heating 2.76 g of silver carbonate?
 (Given : Molar mass of C, O and Ag are 12, 16 and 108 g mol^{-1} respectively)

Options 1. **3.24 g**2. **4.32 g**3. **2.16 g**4. **1.08 g**Question Type : **MCQ**Question ID : **695278351**Option 1 ID : **6952781193**Option 2 ID : **6952781194**Option 3 ID : **6952781192**Option 4 ID : **6952781191**Status : **Answered**Chosen Option : **4**

Q.54 Given below are two statements:

Statement I: Sodium dichromate and potassium dichromate are classified as primary standards in titrimetric analysis.

Statement II: Phenolphthalein is a weak base, therefore it dissociates in acidic medium.

In the light of the above statements, choose the *correct* answer from the options given below

- Options
1. Both Statement I and Statement II are true
 2. Statement I is true but Statement II is false
 3. Statement I is false but Statement II is true
 4. Both Statement I and Statement II are false

Question Type : **MCQ**

Question ID : **695278370**

Option 1 ID : **6952781267**

Option 2 ID : **6952781269**

Option 3 ID : **6952781270**

Option 4 ID : **6952781268**

Status : **Not Answered**

Chosen Option : --

Q.55 Correct statements from the following are:

- A. Nitrogen in oxidation states from +1 to +4 disproportionates in acid medium.
- B. Nitrogen has the ability to form $d\pi - p\pi$ multiple bonds with itself and other elements with small size and high electronegativity.
- C. N-N single bond is stronger than P-P single bond.
- D. Nitrogen has highest density in its group due to small size.
- E. The maximum covalency of nitrogen is four since it has only four valence orbitals for bonding.

Choose the correct answer from the options given below:

- Options
1. C, D and E Only
 2. A and E Only
 3. B, C and D Only
 4. A, C and E Only

Question Type : **MCQ**

Question ID : **695278359**

Option 1 ID : **6952781224**

Option 2 ID : **6952781226**

Option 3 ID : **6952781223**

Option 4 ID : **6952781225**

Status : **Answered**

Chosen Option : **1**

Q.56 Given below are two statements:

Statement I: Each electron in e_g orbitals destabilizes the orbitals by $+0.6 \Delta_o$ and each electron in the t_{2g} orbitals stabilizes the orbitals by $-0.4 \Delta_o$ in an octahedral field on the basis of crystal field theory.

Statement II: All the d - orbitals of the transition metals have the same energy in their free atomic state but when a complex is formed the ligands destroy the degeneracy of these orbitals on the basis of crystal field theory.

In the light of the above statements, choose the **correct** answer from the options given below

- Options
1. Both Statement I and Statement II are incorrect
 2. Statement I is correct but Statement II is incorrect
 3. Statement I is incorrect but Statement II is correct
 4. Both Statement I and Statement II are correct

Question Type : **MCQ**

Question ID : **695278362**

Option 1 ID : **6952781236**

Option 2 ID : **6952781237**

Option 3 ID : **6952781238**

Option 4 ID : **6952781235**

Status : **Answered**

Chosen Option : **2**

Q.57 What is the mole fraction of water in 10% by weight (w/w) of aqueous urea solution?

[Given: Molar mass of H, O, C and N are 1, 16, 12 and 14 g mol^{-1} respectively.]

- Options
1. 0.867
 2. 0.032
 3. 0.825
 4. 0.967

Question Type : **MCQ**

Question ID : **695278354**

Option 1 ID : **6952781205**

Option 2 ID : **6952781204**

Option 3 ID : **6952781203**

Option 4 ID : **6952781206**

Status : **Not Answered**

Chosen Option : **--**

Q.58 Identify the **correct** statements.

- A. Glucose exists in two anomeric forms.
- B. Anomers of glucose differ in configuration at C-1 in cyclic hemiacetal structure.
- C. Melting point of α - anomer of glucose is greater than β - anomer.
- D. Specific rotation of α - anomer is $+19^\circ$ while for β - anomer is $+112^\circ$
- E. α and β - anomers of glucose are prepared by crystallization of saturated glucose solution at 303 K and 371 K respectively.

Choose the correct answer from the options given below:

- Options**
1. A and B Only
 2. A, B and D Only
 3. A, B and E Only
 4. B and C Only

Question Type : **MCQ**

Question ID : **695278369**

Option 1 ID : **6952781263**

Option 2 ID : **6952781265**

Option 3 ID : **6952781266**

Option 4 ID : **6952781264**

Status : **Answered**

Chosen Option : **3**

Q.59 For the following Friedel Craft's alkylation reaction, which of the statements are correct?

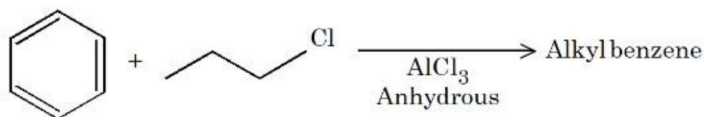

- A. Major product is n-propyl benzene.
- B. iso-propyl carbocation intermediate is also generated.
- C. Multiple substitution is inevitable.
- D. Introducing electron-donating substituent on benzene will not produce any alkyl benzene.

Choose the correct answer from the options given below:

- Options**
1. B and D only
 2. A and D only
 3. B and C only
 4. A and C only

Question Type : **MCQ**

Question ID : **695278365**

Option 1 ID : **6952781250**

Option 2 ID : **6952781247**

Option 3 ID : **6952781248**

Option 4 ID : **6952781249**

Status : **Answered**

Chosen Option : **2**

Q.60 Arrange the following resultant mixtures in increasing order of their pH values

- A. 10 mL 0.2 M Ca(OH)₂ + 25 mL 0.1 M HCl
- B. 10 mL 0.01 M H₂SO₄ + 10 mL 0.01 M Ca(OH)₂
- C. 10 mL 0.1 M H₂SO₄ + 10 mL 0.1 M KOH

Choose the correct answer from the options given below:

- Options**
1. C < A < B
 2. A < C < B
 3. C < B < A
 4. B < C < A

Question Type : **MCQ**

Question ID : **695278356**

Option 1 ID : **6952781212**

Option 2 ID : **6952781214**

Option 3 ID : **6952781213**

Option 4 ID : **6952781211**

Status : **Answered**

Chosen Option : **4**

Q.61 Benzyl isocyanide can be obtained from

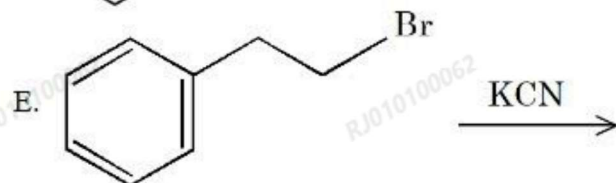
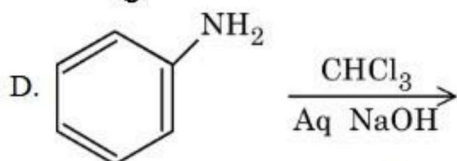
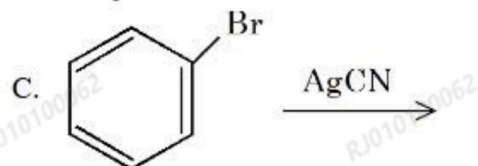
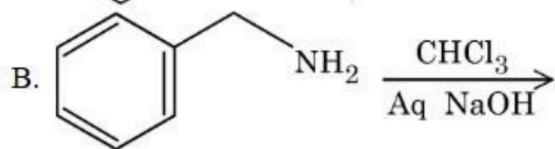
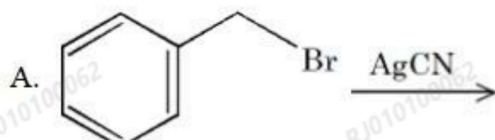

Choose the correct answer from the options given below:

- Options
1. A and B Only
 2. B and D Only
 3. A and C Only
 4. D and E Only

Question Type : **MCQ**

Question ID : **695278366**

Option 1 ID : **6952781251**

Option 2 ID : **6952781253**

Option 3 ID : **6952781252**

Option 4 ID : **6952781254**

Status : **Answered**

Chosen Option : **2**

Q.62 First order gas phase reaction

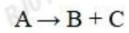

p_i = initial pressure of gas A, p_t = total pressure of the reaction mixture at time t

Expression of rate constant (k) is

Options

1. $\frac{1}{t} \ln \frac{3p_i}{4p_i - p_t}$

2. $\frac{1}{t} \ln \frac{p_i}{2p_i - p_t}$

3. $\frac{1}{t} \ln \frac{p_i}{3p_i - 2p_t}$

4. $\frac{1}{t} \ln \frac{2p_i}{p_i - p_t}$

Question Type : **MCQ**

Question ID : **695278357**

Option 1 ID : **6952781218**

Option 2 ID : **6952781215**

Option 3 ID : **6952781217**

Option 4 ID : **6952781216**

Status : **Answered**

Chosen Option : **2**

Q.63 M_3A_2 is a sparingly soluble salt of molar mass $y \text{ g mol}^{-1}$ and solubility $x \text{ g L}^{-1}$.
The ratio of the molar concentration of the anion (A^{3-}) to the solubility product of the salt is

Options

1. $\frac{y^5}{108x^4}$
2. $108 \cdot \frac{x^5}{y^5}$
3. $\frac{1}{108} \cdot \frac{y^4}{x^4}$
4. $\frac{1}{54} \cdot \frac{y^4}{x^4}$

Question Type : **MCQ**

Question ID : **695278355**

Option 1 ID : **6952781208**

Option 2 ID : **6952781209**

Option 3 ID : **6952781210**

Option 4 ID : **6952781207**

Status : **Not Answered**

Chosen Option : --

Q.64 Which of the following is **NOT** a physical or chemical characteristics of interstitial compounds?

Options

1. They are very soft and ionic in nature.
2. They retain metallic conductivity.
3. They have high melting points, higher than those of pure metals.
4. They are chemically inert and usually non-stoichiometric.

Question Type : **MCQ**

Question ID : **695278360**

Option 1 ID : **6952781228**

Option 2 ID : **6952781229**

Option 3 ID : **6952781227**

Option 4 ID : **6952781230**

Status : **Answered**

Chosen Option : **1**

Q.65 "P" is a hydrocarbon of molecular formula:- C_8H_{14} . On ozonolysis, "P" forms "Q". "Q" on treatment with alkali under reflux condition produces "R", which on treatment with $I_2/NaOH$ gives a yellow precipitate. Acidification of the solution gives "S". The structure of "S" is given below:-

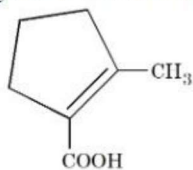

The correct structure of "P" is

Options

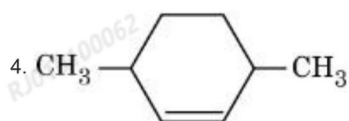
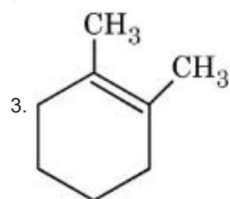
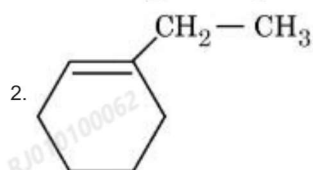
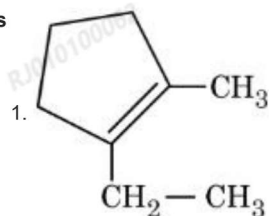

Question Type : **MCQ**

Question ID : **695278364**

Option 1 ID : **6952781245**

Option 2 ID : **6952781244**

Option 3 ID : **6952781246**

Option 4 ID : **6952781243**

Status : **Answered**

Chosen Option : **4**

Q.66 Identify the **incorrect** statements.

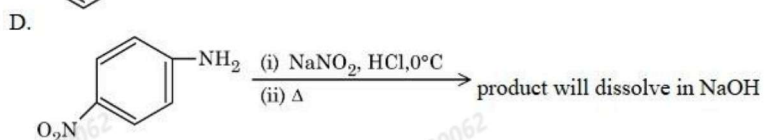
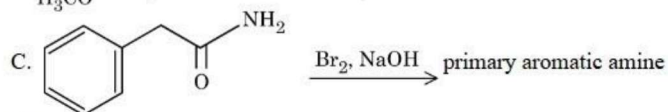
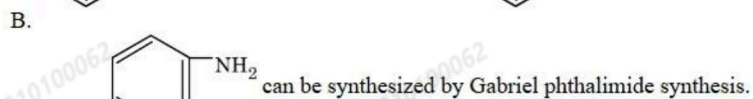
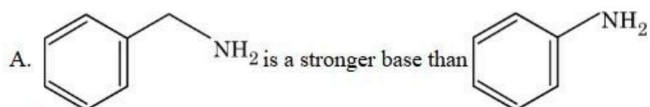

Choose the correct answer from the options given below:

- Options
1. A and B Only
 2. B and C Only
 3. A and C Only
 4. A and D Only

Question Type : **MCQ**

Question ID : **695278368**

Option 1 ID : **6952781262**

Option 2 ID : **6952781261**

Option 3 ID : **6952781260**

Option 4 ID : **6952781259**

Status : **Answered**

Chosen Option : **2**

Q.67 Given below are two statements:

Statement I: The correct order of electronegativity of fluorine, oxygen and nitrogen is $F > O > N$.

Statement II: The oxidation state of oxygen in OF_2 is +2 and in Na_2O is -2.

In the light of the above statements, choose the **correct** answer from the options given below

- Options
1. Statement I is false but Statement II is true
 2. Both Statement I and Statement II are true
 3. Both Statement I and Statement II are false
 4. Statement I is true but Statement II is false

Question Type : **MCQ**

Question ID : **695278358**

Option 1 ID : **6952781222**

Option 2 ID : **6952781219**

Option 3 ID : **6952781220**

Option 4 ID : **6952781221**

Status : **Answered**

Chosen Option : **2**

Q.68 Identify the **correct** statements from the following :

- A. Heisenberg uncertainty principle is applicable to electrons.
- B. The size of $2p_x$ orbital is less than the size of $3p_x$ orbital.
- C. The energy of $2s$ orbital of H atom is equal to the energy of $2s$ orbital of Li.
- D. The electronic configuration of Cr is $[Ar] 3d^5 4s^1$

Choose the correct answer from the options given below:

- Options
1. A, B and D Only
 2. A, B and C Only
 3. B, C and D Only
 4. A, C and D Only

Question Type : **MCQ**

Question ID : **695278353**

Option 1 ID : **6952781200**

Option 2 ID : **6952781199**

Option 3 ID : **6952781201**

Option 4 ID : **6952781202**

Status : **Answered**

Chosen Option : **1**

Q.69 Given below are two statements:

Statement I: On the basis of inductive effect, the order of stability of alkyl carbanions is $\text{CH}_3^- > \text{CH}_3\text{-CH}_2^- > (\text{CH}_3)_2\text{CH}^- > (\text{CH}_3)_3\text{C}^-$.

Statement II: Allyl and benzyl carbanions are more stabilised by inductive effect and not by resonance effect.

In the light of the above statements, choose the *correct* answer from the options given below

- Options
- Both Statement I and Statement II are incorrect
 - Statement I is correct but Statement II is incorrect
 - Statement I is incorrect but Statement II is correct
 - Both Statement I and Statement II are correct

Question Type : **MCQ**

Question ID : **695278363**

Option 1 ID : **6952781240**

Option 2 ID : **6952781241**

Option 3 ID : **6952781242**

Option 4 ID : **6952781239**

Status : **Answered**

Chosen Option : **2**

Q.70 Arrange the following atomic orbitals of multi electron atoms in order of increasing energy.

- $n = 3, l = 2, m = +1$
- $n = 4, l = 0, m = 0$
- $n = 6, l = 1, m = 0$
- $n = 5, l = 1, m = +1$
- $n = 2, l = 1, m = +1$

Choose the correct answer from the options given below:

- Options
- $E < B < A < D < C$
 - $E < C < D < B < A$
 - $B < A < E < C < D$
 - $C < D < B < A < E$

Question Type : **MCQ**

Question ID : **695278352**

Option 1 ID : **6952781198**

Option 2 ID : **6952781197**

Option 3 ID : **6952781196**

Option 4 ID : **6952781195**

Status : **Answered**

Chosen Option : **1**

Section : Chemistry Section B

- Q.71** The values of pressure equilibrium constant recorded at different temperatures for the following equilibrium reaction have been given below
 $A(g) \rightleftharpoons B(g) + C(g)$

$\frac{1}{T} (K^{-1})$	$\log_{10} K_p$
0.05	3.5
0.06	2.5
0.07	1.5

The magnitude of $\frac{\Delta H^\circ}{R}$ calculated from the above data is _____. (Nearest integer)

Given --
 Answer :

Question Type : SA
 Question ID : 695278374
 Status : Not Answered

- Q.72** In an estimation of sulphur by Carius method 0.2 g of the substance gave 0.6 g of $BaSO_4$. The percentage of sulphur in the substance is _____.
 (Given molar mass in $g\ mol^{-1}$ S : 32, $BaSO_4$: 231)

Given --
 Answer :

Question Type : SA
 Question ID : 695278372
 Status : Not Answered

- Q.73** If the half life of a first order reaction is 6.93 minutes then the time required for completion of 99% of the reaction will be _____ minutes .
 (Given : $\log 2 = 0.3010$)

Given --
 Answer :

Question Type : SA
 Question ID : 695278375
 Status : Not Answered

Q.74 One mole of phenol is treated with dilute HNO_3 at 298 K to give a mixture of products. The mixture is separated by steam distillation. The steam volatile compound (X) is separated. The increase in percentage of oxygen in (X) with respect to phenol is $\text{_____} \times 10^{-1} \%$
(Given molar mass in g mol^{-1} H:1, C:12, N:14, O:16)

Given --
Answer :

Question Type : SA
Question ID : 695278373
Status : Not Answered

Q.75 Consider the following species:

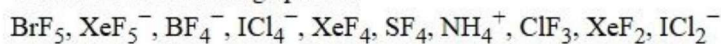

Number of species having sp^3d hybridized central atom is _____.

Given 3
Answer :

Question Type : SA
Question ID : 695278371
Status : Answered

Exam Summary

B. Tech

Section Name	No. of Questions	Answered	Not Answered	Marked for Review	Answered & Marked for Review	Not Visited
Mathematics Section A	20	20	0	0	0	0
Mathematics Section B	5	0	5	0	0	0
Physics Section A	20	20	0	0	0	0
Physics Section B	5	0	5	0	0	0
Chemistry Section A	20	17	3	0	0	0
Chemistry Section B	5	1	4	0	0	0