

MET 2024 Question Paper with Solutions

Time Allowed :2 Hours	Maximum Marks :200	Total Questions :50
-----------------------	--------------------	---------------------

General Instructions

Read the following instructions very carefully and strictly follow them:

- Check the question paper for completeness and correctness of printing. In case of any discrepancy, inform the Invigilator immediately.
- The question paper consists of three sections: Physics, Chemistry, and Mathematics.
- Each section contains both Multiple Choice Questions (MCQs) and Numerical Answer Type questions.
- All MCQs have four options, out of which only one is correct.
- For numerical answer type questions, write the correct numerical value as the answer.
- Each correct answer carries 4 marks.
- There is a negative marking of 1 for incorrect answers in MCQs.
- Attempt all questions within the given time limit.
- Use of calculators, mobile phones, smart watches, or any electronic devices is strictly prohibited.
- Rough work should be done only in the space provided in the question booklet.
- Do not leave the examination hall before the completion of the exam.
- Follow all instructions given by the Invigilator.

PART I - PHYSICS

1. If E = energy, G = gravitational constant, I = impulse and M = mass, then dimensions of $\frac{EI}{GM^2}$ are same as that of:

- (A) time
- (B) mass
- (C) length
- (D) force

2. Two points move in the same straight line starting at the same moment from the same point. One moves with velocity u and the other with acceleration f . The greatest distance between them is:

- (A) $\frac{u}{f}$
 - (B) $\frac{u^2}{2f}$
 - (C) $\frac{f}{2u^2}$
 - (D) $\frac{f}{u^2}$
-

3. A car turns on a road of radius 300 m . Coefficient of friction = 0.3 . Find maximum speed. (Take $g = 10\text{ m/s}^2$)

- (A) 10 m/s
 - (B) 30 m/s
 - (C) 40 m/s
 - (D) 50 m/s
-

4. A particle is projected with speed 4 km/s . Find maximum height (in km). Radius of earth = 6400 km , $g = 9.8\text{ m/s}^2$.

5. The stress versus strain graphs for wires of two materials A and B are as shown. If Y_A and Y_B are the Young's moduli of the materials, then:

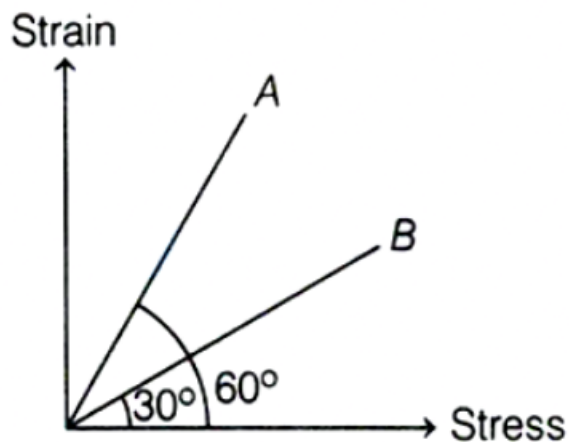

- (A) $Y_B = 2Y_A$
 - (B) $Y_A = Y_B$
 - (C) $Y_B = 3Y_A$
 - (D) $Y_A = 3Y_B$
-

6. Two pendulums of time periods 3 s and 7 s , respectively, start oscillating simultaneously from opposite extreme positions. After how much time will they be in same phase?

- (A) $\frac{21}{8}\text{ s}$
- (B) $\frac{21}{4}\text{ s}$

- (C) $\frac{21}{2} s$
 (D) $\frac{21}{10} s$

7. Fundamental frequency of a sonometer wire is n . If the tension is made 3 times and length and diameter are also increased 3 times, what is the new frequency?

- (A) $\frac{n}{3\sqrt{3}}$
 (B) $3n$
 (C) $\sqrt{3}n$
 (D) $\frac{n}{\sqrt{3}}$

8. An electric dipole shown in the figure. Work done to move a charge particle of $1\mu C$ from point Q to P is $x \times 10^{-7} J$, then the value of x is:

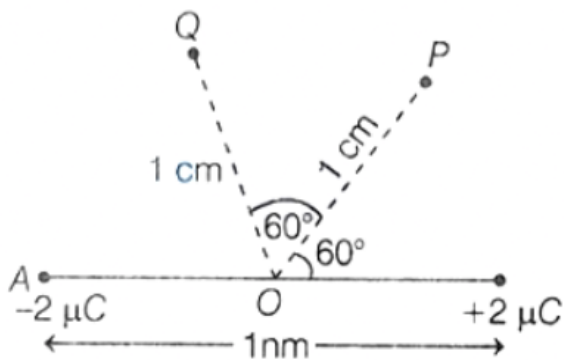

9. In the following circuit diagram, potential difference across $4\mu F$ capacitor is:

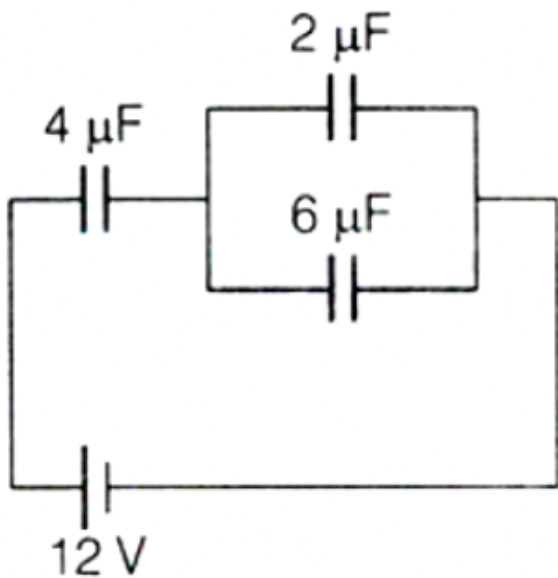

- (A) $19 V$
 - (B) $14 V$
 - (C) $16 V$
 - (D) $8 V$
-

10. An electric kettle has two coils. When one coil is switched on, it takes 10 min to boil water and when the second coil is switched on it takes 20 min to boil same amount of water. The time taken when both coils are used in parallel is n seconds. Find n .

11. When $100 V$ DC is applied across a solenoid, current is $1 A$. When $100 V$ AC is applied, current is $0.5 A$. Frequency = $50 Hz$. Find inductance = $x mH$.

12. When a lens is cut into two halves along XOX' , then focal length of each half lens:

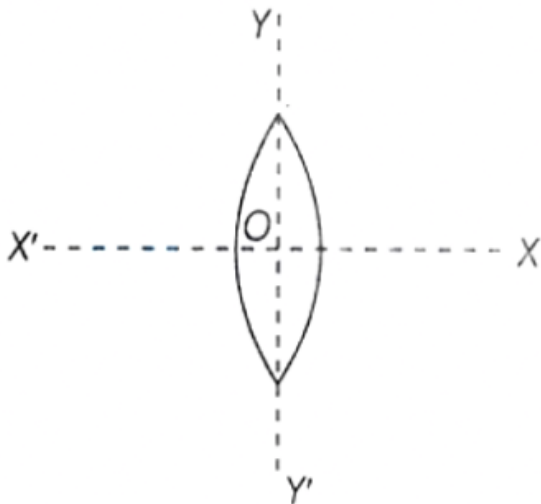

- (A) increases
 - (B) decreases
 - (C) remains same
 - (D) None of the above
-

13. If the frequency of incident photon on a metal surface is doubled, then stopping potential will become:

- (A) doubled
- (B) less than double

- (C) more than double
(D) less than existing value
-

14. If an electron in $n = 4$ orbit of hydrogen atom jumps to $n = 3$, the energy released and wavelength emitted are:

- (A) $0.66 \text{ eV}, 1.88 \times 10^{-6} \text{ m}$
(B) $1.89 \text{ eV}, 1.98 \times 10^{-7} \text{ m}$
(C) $0.29 \text{ eV}, 1.78 \times 10^{-5} \text{ m}$
(D) $0.98 \text{ eV}, 0.93 \times 10^{-6} \text{ m}$
-

15. In the circuit shown, diode has 20Ω forward resistance. When V_i increases from 8V to 12V , change in current is $x \text{ mA}$. Find x .



PART II - CHEMISTRY

1. The wave number of the shortest wavelength of absorption spectrum of hydrogen atom is ----

(Rydberg constant = 109700 cm^{-1}).

2. Electronegativity of the following elements increases in the order:

- (A) C, N, Si, P
(B) N, Si, C, P
(C) Si, P, C, N
(D) P, Si, N, C
-

3. Match List-I (Compound) with List-II (Hybridisation):

List-I	List-II
A. CuCl_5^{3-}	I. sp^3d^2
B. MnCl_5^{3-}	II. d^2sp^3
C. XeOF_4	III. dsp^3
D. $\text{Fe}(\text{CO})_5$	IV. sp^3d

Choose the correct match:

- (A) A-IV, B-III, C-I, D-II
 - (B) A-IV, B-III, C-II, D-I
 - (C) A-IV, B-I, C-III, D-II
 - (D) A-IV, B-II, C-III, D-I
-

4. The spin only magnetic moment of $[NiCl_4]^{2-}$ is ____ (Nearest integer).

5. The maximum work obtained from a reversible process is given as:

- (A) $-\Delta A$
 - (B) ΔA
 - (C) $-\Delta G$
 - (D) ΔG
-

6. If K_p for the reaction $A(g) + 2B(g) \rightleftharpoons 3C(g) + D(g)$ is 0.05 atm at 1000 K, its K_c in terms of $\frac{x \times 10^{-5}}{R}$. Find x .

7. Boiling point of water at 750 mmHg is 99.63°C. The amount of sucrose to be added to 500 g water so that it boils at 100°C is ____ g. (Molar elevation constant $K_b = 0.5 \text{ K kg mol}^{-1}$)

8. For the cell reaction,

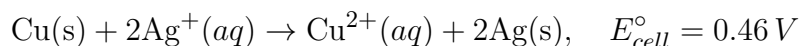

The equilibrium constant of the reaction is:

- (A) 3.92×10^{12}
 - (B) 3.92×10^{15}
 - (C) 8.92×10^{17}
 - (D) 8.92×10^{10}
-

9. For a first order reaction, time required for 99% completion is x times the time required for 90% completion. Find x .

10. F_2 is formed by reacting K_2MnF_6 with:

- (A) SbF_5
- (B) MnF_3

- (C) $K\text{SbF}_6$
(D) MnF_4
-

11. Which of the following ion is colourless inspite of the presence of unpaired electrons?

- (A) La^{3+}
(B) Eu^{3+}
(C) Gd^{3+}
(D) Lu^{3+}
-

12. The oxidation state of Cr in $[\text{Cr}(\text{H}_2\text{O})_6]\text{Cl}_3$, $[\text{Cr}(\text{C}_6\text{H}_6)_2]$, $\text{K}_2[\text{Cr}(\text{CN})_2(\text{O})_2(\text{O}_2)(\text{NH}_3)]$ respectively are:

- (A) +3, +4, +6
(B) +3, +2, +4
(C) +3, 0, +6
(D) +3, 0, +4
-

13. In the following sequence of reactions,

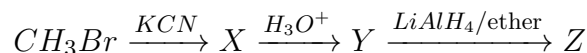

The final product Z is:

- (A) acetone
(B) methane
(C) acetaldehyde
(D) ethyl alcohol
-

14. The major product Y in the following reaction is:

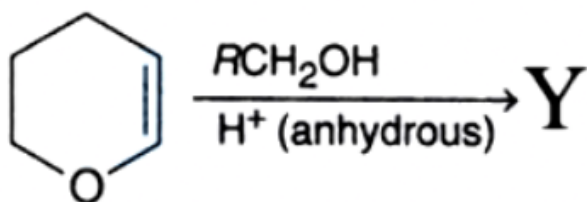

- (A) hemiacetal
(B) acetal
(C) an ether
(D) an ester
-

15. Consider the following amino acids:

- (i) Lysine
- (ii) Glutamine
- (iii) Arginine
- (iv) Leucine
- (v) Serine
- (vi) Proline
- (vii) Valine

Which of the given amino acids are basic in nature?

- (A) (i) and (iii)
 - (B) (i), (ii) and (iv)
 - (C) (iii) and (vii)
 - (D) (iii), (v) and (vi)
-

PART III - MATHEMATICS

1. The solution of the equation $\log(\log_4(\sqrt{x+4} + \sqrt{x})) = 0$ is:

- (A) 2
 - (B) 4
 - (C) $\frac{9}{4}$
 - (D) 8
-

2. If $\frac{a}{b} = \frac{1}{3}$ and $\frac{b}{c} = \frac{3}{4}$, then the value of $\frac{a+2b}{b+2c}$ is:

- (A) $\frac{28}{33}$
 - (B) $\frac{7}{11}$
 - (C) $\frac{1}{2}$
 - (D) None of these
-

3. Total number of even divisors of 2079000 which are divisible by 15 are:

- (A) 54
 - (B) 128
 - (C) 108
 - (D) 72
-

4. If N denotes number of 8-digit numbers that contain exactly four nines, then unit digit of N is:

5. If the expression $x + \frac{1}{x^2}$, $x > 0$ attains minimum value at $x = \alpha$, then α^3 is:

6. If the number of terms in the expansion of $(x\sqrt{180} + \sqrt[3]{432})^{200}$ having integral coefficients is n , then the value of $[n/6]$ is:

- (A) 4
 - (B) 5
 - (C) 6
 - (D) 7
-

7. If the coefficient of x^m in the expansion of $(\sqrt{2x} + \sqrt[3]{\frac{3}{x^2}})^9$ is equal to k , then k is:

- (A) 1008
 - (B) 2016
 - (C) 3024
 - (D) 1016
-

8. If the angle between the pair of straight lines formed by joining the points of intersection of $x^2 + y^2 = 4$ and $y = 3x + c$ to the origin is a right angle, then c^2 is:

- (A) 20
 - (B) 13
 - (C) $\frac{1}{5}$
 - (D) 5
-

9. The equation of mirror image of the circle $x^2 + y^2 - 6x - 10y + 33 = 0$ about the line $y = x$ is:

- (A) $x^2 + y^2 - 10x + 6y + 33 = 0$
 - (B) $x^2 + y^2 + 10x - 6y + 33 = 0$
 - (C) $x^2 + y^2 - 10x - 6y + 33 = 0$
 - (D) $x^2 + y^2 + 10x + 6y + 33 = 0$
-

10. If two tangents from point (h, k) to parabola $y^2 = 64x$ have slopes such that one is 8 times the other, then value of $\frac{k^2}{2h}$ is:

- (A) 9
 - (B) 27
 - (C) 81
 - (D) 162
-

11. Let $f(x) = \left[\frac{\sin x}{x} \right] + \left[\frac{2 \sin x}{x} \right] + \dots + \left[\frac{10 \sin x}{x} \right]$ (where $[\]$ is the greatest integer function). Find $\lim_{x \rightarrow 0} f(x)$.

12. If in a $\triangle ABC$, $\sin^2 A + \sin^2 B + \sin^2 C = 2$, then the triangle is always:

- (A) isosceles triangle
 - (B) right angled
 - (C) acute angled
 - (D) obtuse angled
-

13. In $\triangle ABC$, $\sin A, \sin B, \sin C$ are in A.P. and $C > 90^\circ$. Then $\cos A$ is:

- (A) $\frac{3c-4b}{2b}$
 - (B) $\frac{3c-4b}{2c}$
 - (C) $\frac{4c-3b}{2b}$
 - (D) $\frac{4c-3b}{2c}$
-

14. Let $D = \begin{vmatrix} n & n^2 & n^3 \\ n^2 & n^3 & n^5 \\ 1 & 2 & 3 \end{vmatrix}$. Then $\lim_{n \rightarrow \infty} \frac{M_{11} + C_{33}}{(M_{13})^2}$ is:

- (A) 0
 - (B) -1
 - (C) -2
 - (D) 3
-

15. If $x = \sin(2 \tan^{-1} 2)$, $y = \sin\left(\frac{1}{2} \tan^{-1} \frac{4}{3}\right)$, then:

- (A) $x = 1 - y$
 - (B) $x^2 = 1 - y$
 - (C) $x^2 = 1 + y$
 - (D) $y^2 = 1 - x$
-

16. Let $f : \mathbb{N} \rightarrow \mathbb{N}$ be defined as

$$f(n) = \begin{cases} \frac{n+1}{2}, & \text{if } n \text{ is odd} \\ \frac{n}{2}, & \text{if } n \text{ is even} \end{cases}$$

Then f is:

- (A) injective but not surjective
- (B) surjective but not injective
- (C) both injective and surjective
- (D) neither injective nor surjective

17. Let $f(x)$ be a polynomial such that $f(x) + f(1/x) = f(x)f(1/x)$, $x > 0$. If $\int f(x)dx = g(x) + c$ and $g(1) = \frac{4}{3}$, $f(3) = 10$, then $g(3)$ is:

- (A) 10
- (B) 9
- (C) 8
- (D) 12

18. A real differentiable function f satisfies $f(x) + f(y) + 2xy = f(x + y)$. Given $f''(0) = 0$, then

$$\int_0^{\pi/2} f(\sin x) dx =$$

- (A) 0
- (B) $\frac{\pi}{4}$
- (C) $\frac{\pi}{2}$
- (D) π

19. Given $\frac{dy}{dx} + 2y \tan x = \sin x$, $y = 0$ at $x = \frac{\pi}{3}$. If maximum value of y is $1/k$, find k .

20. Given vectors $\vec{a}, \vec{b}, \vec{c}$ are non-collinear and $(\vec{a} + \vec{b})$ is collinear with $(\vec{b} + \vec{c})$ which is collinear with \vec{a} , and $|\vec{a}| = |\vec{b}| = |\vec{c}| = \sqrt{2}$, find $|\vec{a} + \vec{b} + \vec{c}|$.
