

NEET-UG Physics Sample Paper-11

Duration: 1 Hour

Maximum Marks: 180

Instructions

- This paper contains a total of **45** Multiple Choice Questions.
- Each correct answer carries **+5 marks**.
- Each incorrect answer carries **-1 mark**.
- No negative marking for unattempted questions.

Q1. A screw gauge gives the following readings when used to measure the diameter of a wire: Main scale reading: 0 mm; Circular scale reading: 52 divisions. Given that 1 mm on the main scale corresponds to 100 divisions on the circular scale. The diameter of the wire from the above data is:

- (A) 0.052 cm
- (B) 0.026 cm
- (C) 0.005 cm
- (D) 0.52 cm

Q2. A particle moves in a straight line such that its displacement x at any time t is given by $x^2 = t^2 + 1$. The acceleration of the particle at any time t is:

- (A) $\frac{1}{x}$
- (B) $\frac{1}{x^2}$
- (C) $\frac{1}{x^3}$
- (D) $-\frac{1}{x^2}$

Q3. A projectile is fired at an angle of 45° with the horizontal. Elevation angle of the projectile at its highest point as seen from the point of projection is:

- (A) 60°



- (B) $\tan^{-1} \left(\frac{1}{2} \right)$
- (C) $\tan^{-1} \left(\frac{\sqrt{3}}{2} \right)$
- (D) 45°

Q4. A block of mass M is pulled along a horizontal frictionless surface by a rope of mass m . If a force F is applied at one end of the rope, the force which the rope exerts on the block is:

- (A) $\frac{FM}{M+m}$
- (B) $\frac{Fm}{M+m}$
- (C) $\frac{F(M+m)}{M}$
- (D) F

Q5. A ball of mass 0.15 kg is dropped from a height 10 m, strikes the ground and rebounds to the same height. The magnitude of impulse imparted to the ball is ($g = 10 \text{ m/s}^2$) nearly:

- (A) 0 kg m/s
- (B) 4.2 kg m/s
- (C) 2.1 kg m/s
- (D) 1.4 kg m/s

Q6. A particle moves from a point $(-2\hat{i} + 5\hat{j})$ to $(4\hat{j} + 3\hat{k})$ when a force of $(4\hat{i} + 3\hat{j})$ N is applied. How much work has been done by the force?

- (A) 8 J
- (B) 11 J
- (C) 5 J
- (D) 2 J
- (E) 10 J



- Q7.** A potential energy function for a two-dimensional force is of the form $U = 3x^3y - 7x$. The force component F_x is:
- (A) $3x^2y - 7$
 - (B) $7 - 9x^2y$
 - (C) $9x^2y - 7$
 - (D) $3x^3$
- Q8.** A solid sphere of mass m and radius R is rotating about its diameter. A solid cylinder of the same mass and same radius is also rotating about its geometrical axis with an angular speed twice that of the sphere. The ratio of their kinetic energies of rotation ($E_{sphere}/E_{cylinder}$) is:
- (A) 1 : 4
 - (B) 1 : 5
 - (C) 2 : 3
 - (D) 1 : 8
- Q9.** A circular disc of radius r and thickness $r/6$ has moment of inertia I about an axis passing through its center and perpendicular to its plane. It is melted and recasted into a solid sphere. The moment of inertia of the sphere about its diameter is:
- (A) $I/5$
 - (B) $I/10$
 - (C) $I/2$
 - (D) $I/12$
- Q10.** The escape velocity from the Earth is 11.2 km/s. The escape velocity from a planet having twice the radius and the same mean density as the Earth is:
- (A) 11.2 km/s



- (B) 22.4 km/s
- (C) 15 km/s
- (D) 5.6 km/s

Q11. Two satellites of Earth S_1 and S_2 are moving in the same orbit. The mass of S_1 is four times the mass of S_2 . Which one of the following statements is true?

- (A) The potential energies of Earth and satellite in the two cases are equal.
- (B) S_1 and S_2 are moving with the same speed.
- (C) The kinetic energies of the two satellites are equal.
- (D) The time period of S_1 is four times that of S_2 .

Q12. [Image: A U-tube contains water and spirit separated by mercury. The mercury columns in the two arms are in level with 10 cm of water in one arm and 12.5 cm of spirit in the other.] What is the specific gravity of spirit?

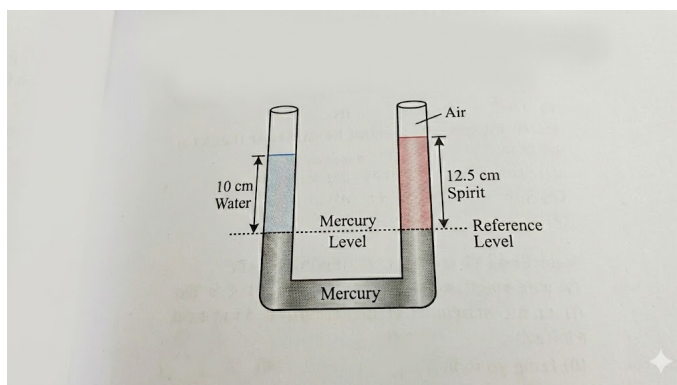

- (A) 0.8
- (B) 0.6
- (C) 1.25
- (D) 0.4

Q13. A small spherical ball of radius r falls from rest in a viscous liquid. Due to friction, heat is produced. The rate of production of heat when the ball attains terminal velocity is proportional to:



- (A) r^3
- (B) r^2
- (C) r^5
- (D) r^4

Q14. A copper rod of 88 cm and an aluminum rod of unknown length have their increase in length independent of increase in temperature. The length of aluminum rod is ($\alpha_{Cu} = 1.7 \times 10^{-5} \text{ K}^{-1}$ and $\alpha_{Al} = 2.2 \times 10^{-5} \text{ K}^{-1}$):

- (A) 68 cm
- (B) 113.9 cm
- (C) 88 cm
- (D) 44 cm

Q15. One mole of an ideal gas at an initial temperature of T K does $6R$ joules of work adiabatically. If the ratio of specific heats of this gas is $5/3$, the final temperature of gas will be:

- (A) $(T - 4)$ K
- (B) $(T + 4)$ K
- (C) $(T - 8)$ K
- (D) $(T + 8)$ K

Q16. A thermodynamic system is taken through a cyclic process $ABCD$ as shown in the $P - V$ diagram. The net work done by the system in one cycle is: [Image: A rectangular PV graph with points $A(V, 3P)$, $B(4V, 3P)$, $C(4V, P)$, and $D(V, P)$]

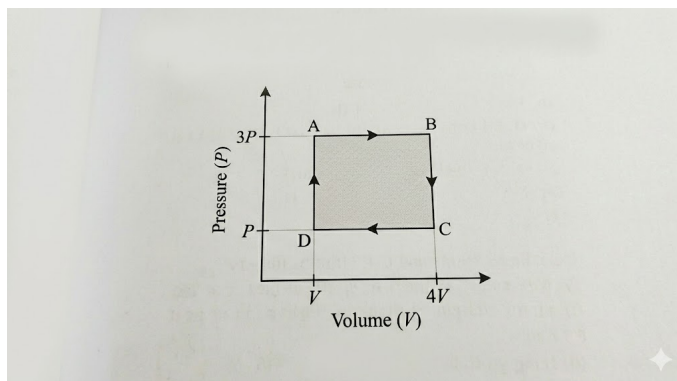

- (A) $3PV$
- (B) $6PV$
- (C) $9PV$
- (D) $12PV$

Q17. The root mean square speed of the molecules of a diatomic gas is v . When the temperature is doubled, the molecules dissociate into two atoms. The new root mean square speed of the atoms is:

- (A) v
- (B) $v\sqrt{2}$
- (C) $2v$
- (D) $4v$

Q18. A particle is executing SHM along a straight line. Its velocities at distances x_1 and x_2 from the mean position are v_1 and v_2 respectively. Its time period is:

- (A) $2\pi\sqrt{\frac{v_1^2 - v_2^2}{x_2^2 - x_1^2}}$
- (B) $2\pi\sqrt{\frac{x_2^2 - x_1^2}{v_1^2 - v_2^2}}$
- (C) $2\pi\sqrt{\frac{x_1^2 + x_2^2}{v_1^2 + v_2^2}}$
- (D) $2\pi\sqrt{\frac{v_1^2 + v_2^2}{x_1^2 + x_2^2}}$

Q19. The damping force on an oscillator is directly proportional to the velocity. The units of the constant of proportionality are:

- (A) kg s^{-1}
- (B) kg m s^{-1}
- (C) kg m s^{-2}
- (D) kg s



- Q20.** Two point charges A and B , having charges $+Q$ and $-Q$ respectively, are placed at certain distance apart and force acting between them is F . If 25% charge of A is transferred to B , then force between the charges becomes:
- (A) F
(B) $\frac{9F}{16}$
(C) $\frac{16F}{9}$
(D) $\frac{4F}{3}$
- Q21.** A parallel plate capacitor with air between the plates has a capacitance of 9 pF. The separation between its plates is d . The space between the plates is now filled with two dielectric slabs. One slab has dielectric constant $K_1 = 3$ and thickness $d/3$, and the other slab has dielectric constant $K_2 = 6$ and thickness $2d/3$. The capacitance of the capacitor is now:
- (A) 18 pF
(B) 45 pF
(C) 40.5 pF
(D) 20.25 pF
- Q22.** A spherical conductor of radius 10 cm has a charge of 3.2×10^{-7} C distributed uniformly on its surface. What is the magnitude of electric field at a point 15 cm from the centre of the sphere? ($\frac{1}{4\pi\epsilon_0} = 9 \times 10^9 \text{ Nm}^2/\text{C}^2$)
- (A) $1.28 \times 10^4 \text{ N/C}$
(B) $1.28 \times 10^5 \text{ N/C}$
(C) $1.28 \times 10^6 \text{ N/C}$
(D) $1.28 \times 10^7 \text{ N/C}$
- Q23.** In a potentiometer circuit, a cell of EMF 1.5 V gives a balance point at 36 cm length of wire. If another cell of EMF 2.5 V replaces the first cell, then at what length of the wire will the balance point occur?



- (A) 60 cm
- (B) 21.6 cm
- (C) 64 cm
- (D) 62 cm

Q24. The resistance of a wire is R ohm. If it is melted and stretched to n times its original length, its new resistance will be:

- (A) nR
- (B) $\frac{R}{n}$
- (C) n^2R
- (D) $\frac{R}{n^2}$

Q25. [Image: A circuit diagram consisting of a 12 V battery connected to a network of four resistors: $R_1 = 2\Omega$, $R_2 = 4\Omega$ in parallel, which are in series with $R_3 = 1\Omega$ and $R_4 = 5\Omega$]. The total current flowing in the circuit is:

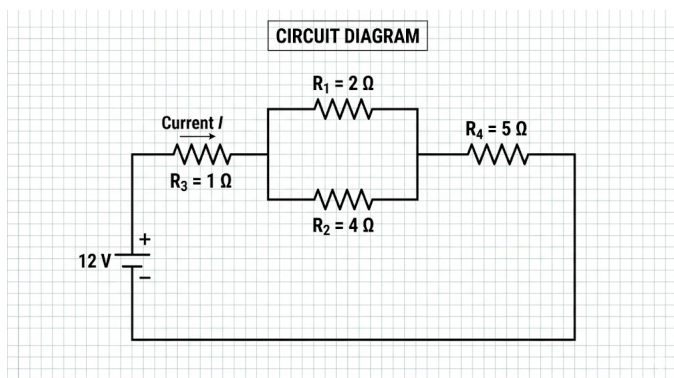

- (A) 1.65 A
- (B) 2.4 A
- (C) 1.2 A
- (D) 3.0 A

Q26. A long solenoid has 1000 turns. When a current of 4 A flows through it, the magnetic flux linked with each turn of the solenoid is 4×10^{-3} Wb. The self-inductance of the solenoid is:



- (A) 4 H
- (B) 3 H
- (C) 2 H
- (D) 1 H

Q27. A charged particle moves through a magnetic field perpendicular to its direction. Then:

- (A) The momentum changes but the kinetic energy is constant.
- (B) Both momentum and kinetic energy change.
- (C) Both momentum and kinetic energy are constant.
- (D) Kinetic energy changes but the momentum is constant.

Q28. A circular coil of radius 10 cm, 500 turns and resistance 2Ω is placed with its plane perpendicular to the horizontal component of the earth's magnetic field. It is rotated about its vertical diameter through 180° in 0.25 s. The induced EMF in the coil is ($B_H = 3 \times 10^{-5}$ T):

- (A) 3.8×10^{-3} V
- (B) 1.9×10^{-3} V
- (C) 5.7×10^{-3} V
- (D) 0.38×10^{-3} V

Q29. The magnetic susceptibility is negative for:

- (A) Paramagnetic materials only
- (B) Diamagnetic materials only
- (C) Ferromagnetic materials only
- (D) Paramagnetic and ferromagnetic materials



- Q30.** [Image: A wire in the shape of a semi-circle of radius R lies in the xy -plane and carries a current I from left to right. A uniform magnetic field B is directed along the positive z -axis]. The magnitude of the magnetic force on the wire is:

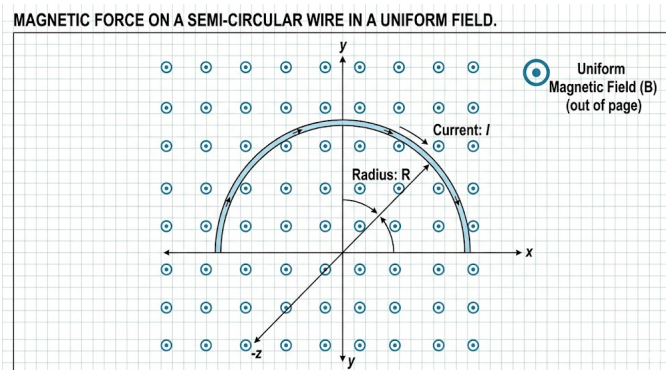

- (A) $2IRB$
- (B) πIRB
- (C) IRB
- (D) Zero
- Q31.** A series LCR circuit is connected to an AC voltage source. When L is removed from the circuit, the phase difference between current and voltage is $\pi/3$. If instead C is removed from the circuit, the phase difference is again $\pi/3$ between current and voltage. The power factor of the circuit is:
- (A) 0.5
- (B) 1.0
- (C) zero
- (D) 0.866
- Q32.** In an electromagnetic wave, the amplitude of the electric field is 48 V/m . The amplitude of the magnetic field is:

- (A) $1.6 \times 10^{-7} \text{ T}$
- (B) $1.6 \times 10^{-8} \text{ T}$
- (C) $16 \times 10^{-7} \text{ T}$



(D) $16 \times 10^{-8} \text{ T}$

Q33. A ray of light is incident at an angle of i on one face of a prism of small angle A and emerges normally from the other face. If the refractive index of the material of the prism is μ , then the angle of incidence is nearly equal to:

(A) A/μ

(B) $A/2\mu$

(C) μA

(D) $\frac{\mu A}{2}$

Q34. An object is placed at a distance of 40 cm from a concave mirror of focal length 15 cm. If the object is displaced through a distance of 20 cm towards the mirror, the displacement of the image will be:

(A) 30 cm away from the mirror

(B) 36 cm away from the mirror

(C) 30 cm towards the mirror

(D) 36 cm towards the mirror

Q35. [Image: A diagram showing a biconvex lens of focal length f being cut into two identical plano-convex lenses along the vertical plane.] If the original lens has a power P , what is the power of each resulting plano-convex lens?

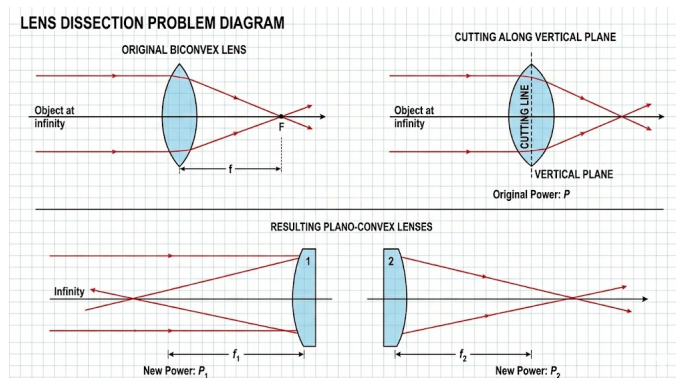

(A) P



- (B) $2P$
- (C) $P/2$
- (D) $P/4$

Q36. In a Young's double slit experiment, the path difference at a certain point on the screen between two interfering waves is $\frac{1}{8}$ th of the wavelength. The ratio of the intensity at this point to that at the center of a bright fringe is:

- (A) 0.853
- (B) 0.5
- (C) 0.707
- (D) 0.924

Q37. The threshold frequency for a photosensitive metal is 3.3×10^{14} Hz. If light of frequency 8.2×10^{14} Hz is incident on this metal, the cutoff voltage for the photoelectric emission is nearly:

- (A) 2 V
- (B) 3 V
- (C) 5 V
- (D) 1 V

Q38. An electron is accelerated from rest through a potential difference of V volt. If the de Broglie wavelength of the electron is 1.227×10^{-2} nm, the potential difference is:

- (A) 10 V
- (B) 10^2 V
- (C) 10^3 V
- (D) 10^4 V



Q39. The ratio of wavelengths of the last line of Balmer series and the last line of Lyman series is:

- (A) 1
- (B) 4
- (C) 0.5
- (D) 2

Q40. [Image: A graph showing the variation of stopping potential V_0 with frequency ν for two different photosensitive materials A and B . Curve B is shifted to the right of curve A with a greater threshold frequency.] Which of the following statements is correct?

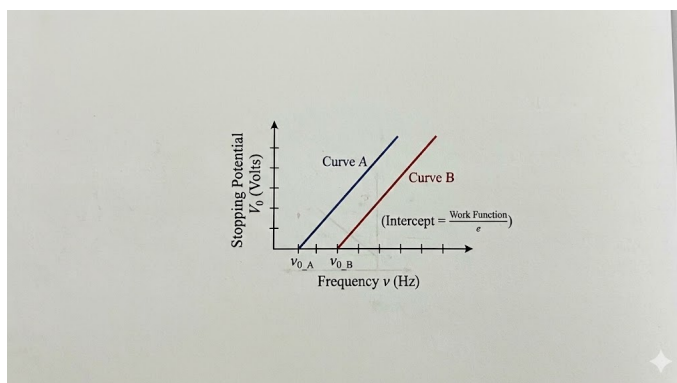

- (A) Work function of A is greater than B .
- (B) Work function of B is greater than A .
- (C) Both have the same work function.
- (D) Slope of curve A is greater than slope of curve B .

Q41. The half-life of a radioactive substance is 30 minutes. The time (in minutes) taken between 40% decay and 85% decay of the same radioactive substance is:

- (A) 15
- (B) 30
- (C) 45
- (D) 60



- Q42.** In a common emitter (CE) amplifier, the audio signal voltage across the collector resistance of $2\text{ k}\Omega$ is 2 V . Suppose the current amplification factor of the transistor is 100. If the base resistance is $1\text{ k}\Omega$, then the input signal voltage is:
- (A) 10 mV
(B) 20 mV
(C) 30 mV
(D) 15 mV
- Q43.** The output Y of the logic circuit shown in the figure is: [Image: A logic circuit consisting of two inputs A and B. A and B are connected to a NAND gate, and the output of the NAND gate is fed into both inputs of a second NAND gate acting as a NOT gate.]
- (A) $A \cdot B$
(B) $\overline{A \cdot B}$
(C) $A + B$
(D) $\overline{A + B}$
- Q44.** In a $p - n$ junction diode, change in temperature due to heating:
- (A) affects only forward resistance
(B) affects only reverse resistance
(C) affects the overall $V - I$ characteristics
(D) does not affect resistance of $p - n$ junction
- Q45.** In an experiment to find the focal length of a convex mirror, a convex lens of focal length f_L is used. The object is placed at a distance a from the lens. The mirror is placed behind the lens such that the image formed by the lens-mirror combination coincides with the object. If the distance between the lens and the mirror is d , the focal length of the convex mirror is:



(A) $\frac{af_L}{a-f_L} - d$

(B) $\frac{1}{2} \left[\frac{af_L}{a-f_L} - d \right]$

(C) $\frac{af_L}{a+f_L} - d$

(D) $\frac{1}{2} \left[\frac{af_L}{a+f_L} - d \right]$



Detailed Solutions**Q1.****Solution****Concept:**

The least count (LC) of a screw gauge is defined as the ratio of the pitch to the total number of divisions on the circular scale. The total reading is calculated as:

$$\text{Total Reading} = \text{Main Scale Reading (MSR)} + (\text{Circular Scale Reading (CSR)} \times \text{LC})$$

Solution:

1. First, find the Pitch. The problem states 1 mm on the main scale corresponds to 100 divisions (implying one full rotation moves 1 mm if the scale is standard, or simply given the scale ratio).
2. The Least Count (LC) is:

$$LC = \frac{1 \text{ mm}}{100} = 0.01 \text{ mm}$$

3. Given MSR = 0 mm and CSR = 52 divisions. 4. The diameter (Total Reading) is:

$$\text{Diameter} = 0 + (52 \times 0.01 \text{ mm}) = 0.52 \text{ mm}$$

5. Convert the result to centimeters (cm):

$$0.52 \text{ mm} = \frac{0.52}{10} \text{ cm} = 0.052 \text{ cm}$$

Final Answer: The diameter of the wire is 0.052 cm.

Answer: (A)



Q2.

Solution**Concept:**

Acceleration is the second derivative of displacement with respect to time. For a function defined implicitly as $x^2 = f(t)$, we use chain rule differentiation.

Solution:

1. Given the equation:

$$x^2 = t^2 + 1$$

2. Differentiate both sides with respect to t :

$$2x \frac{dx}{dt} = 2t$$

$$xv = t \implies v = \frac{t}{x}$$

3. Differentiate again with respect to t to find acceleration (a):

$$\frac{d}{dt}(xv) = \frac{d}{dt}(t)$$

$$x \frac{dv}{dt} + v \frac{dx}{dt} = 1$$

$$xa + v^2 = 1$$

4. Substitute $v = \frac{t}{x}$ into the equation:

$$xa + \left(\frac{t}{x}\right)^2 = 1$$

$$xa = 1 - \frac{t^2}{x^2} = \frac{x^2 - t^2}{x^2}$$

5. From the original equation $x^2 - t^2 = 1$. Substitute this:

$$xa = \frac{1}{x^2} \implies a = \frac{1}{x^3}$$

Final Answer: The acceleration is $1/x^3$.

Answer: (C)



Q3.

Solution**Concept:**

The elevation angle (ϕ) is the angle made by the line joining the point of projection to the highest point with the horizontal. This is different from the projection angle (θ).

Solution:

1. At the highest point, the coordinates are $(R/2, H)$, where R is range and H is maximum height.
2. The tangent of the elevation angle ϕ is:

$$\tan \phi = \frac{H}{R/2} = \frac{2H}{R}$$

3. We know the formulas for H and R :

$$H = \frac{u^2 \sin^2 \theta}{2g}, \quad R = \frac{u^2 \sin 2\theta}{g} = \frac{2u^2 \sin \theta \cos \theta}{g}$$

4. Substitute these into the expression for $\tan \phi$:

$$\tan \phi = 2 \left(\frac{u^2 \sin^2 \theta}{2g} \right) \times \left(\frac{g}{2u^2 \sin \theta \cos \theta} \right)$$

$$\tan \phi = \frac{\sin \theta}{2 \cos \theta} = \frac{1}{2} \tan \theta$$

5. Given $\theta = 45^\circ$, $\tan 45^\circ = 1$:

$$\tan \phi = \frac{1}{2}(1) = \frac{1}{2} \implies \phi = \tan^{-1} \left(\frac{1}{2} \right)$$

Final Answer: The elevation angle is $\tan^{-1}(1/2)$.

Answer: (B)



Q4.

Solution**Concept:**

When a system of masses is pulled, the entire system moves with a common acceleration (a). The internal force (tension) between components depends on the mass being accelerated behind the point of contact.

Solution:

1. Total mass of the system (rope + block) = $M + m$. 2. The acceleration a of the whole system is:

$$a = \frac{F}{M + m}$$

3. To find the force the rope exerts on the block, consider the free body diagram (FBD) of the block. 4. The only horizontal force acting on the block of mass M is the tension/force from the rope (T). 5. Using Newton's second law for the block:

$$T = M \times a$$

6. Substitute the value of a :

$$T = M \left(\frac{F}{M + m} \right) = \frac{FM}{M + m}$$

Final Answer: The force is $FM/(M + m)$.

Answer: (A)



Q5.

Solution**Concept:**

Impulse (J) is defined as the change in momentum: $J = \Delta p = m(v_f - v_i)$. Since the ball rebounds to the same height, the speed of impact equals the speed of rebound, but the direction is reversed.

Solution:

1. Calculate the velocity just before hitting the ground (v_i):

$$v_i = \sqrt{2gh} = \sqrt{2 \times 10 \times 10} = \sqrt{200} = 10\sqrt{2} \text{ m/s (downwards)}$$

2. Since it rebounds to the same height, the velocity just after impact (v_f) is:

$$v_f = 10\sqrt{2} \text{ m/s (upwards)}$$

3. Taking upwards as positive, the change in velocity is:

$$\Delta v = v_f - v_i = 10\sqrt{2} - (-10\sqrt{2}) = 20\sqrt{2} \text{ m/s}$$

4. Calculate impulse:

$$J = m\Delta v = 0.15 \times 20\sqrt{2} = 3\sqrt{2} \text{ kg m/s}$$

5. Using $\sqrt{2} \approx 1.414$:

$$J = 3 \times 1.414 = 4.242 \text{ kg m/s}$$

Final Answer: The magnitude of impulse is approximately 4.2 kg m/s.

Answer: (B)



Q6.

Solution**Concept:**

Work done by a constant force is defined as the dot product of the force vector and the displacement vector:

$$W = \vec{F} \cdot \vec{d}$$

where $\vec{d} = \vec{r}_2 - \vec{r}_1$.

Solution:

1. Identify the initial position vector \vec{r}_1 and final position vector \vec{r}_2 :

$$\vec{r}_1 = -2\hat{i} + 5\hat{j}$$

$$\vec{r}_2 = 4\hat{j} + 3\hat{k}$$

2. Calculate the displacement vector \vec{d} :

$$\vec{d} = \vec{r}_2 - \vec{r}_1 = (0 - (-2))\hat{i} + (4 - 5)\hat{j} + (3 - 0)\hat{k}$$

$$\vec{d} = 2\hat{i} - \hat{j} + 3\hat{k}$$

3. The force vector is given as:

$$\vec{F} = 4\hat{i} + 3\hat{j} + 0\hat{k}$$

4. Calculate the work done using the dot product:

$$W = \vec{F} \cdot \vec{d} = (4)(2) + (3)(-1) + (0)(3)$$

$$W = 8 - 3 + 0 = 5 \text{ J}$$

Final Answer: The work done is 5 J.

Answer: (C)



Q7.

Solution**Concept:**

The conservative force \vec{F} is related to the potential energy U by the negative gradient:

$$\vec{F} = -\nabla U$$

The x-component of the force is given by the negative partial derivative of U with respect to x :

$$F_x = -\frac{\partial U}{\partial x}$$

Solution:

1. The given potential energy function is:

$$U = 3x^3y - 7x$$

2. Differentiate U partially with respect to x (treating y as a constant):

$$\frac{\partial U}{\partial x} = \frac{\partial}{\partial x}(3x^3y) - \frac{\partial}{\partial x}(7x)$$

$$\frac{\partial U}{\partial x} = (3 \times 3x^2)y - 7 = 9x^2y - 7$$

3. Apply the negative sign to find the force component F_x :

$$F_x = -\left(\frac{\partial U}{\partial x}\right) = -(9x^2y - 7)$$

$$F_x = 7 - 9x^2y$$

Final Answer: The force component F_x is $7 - 9x^2y$.

Answer: (B)



Q8.

Solution**Concept:**

The rotational kinetic energy (K) is given by:

$$K = \frac{1}{2}I\omega^2$$

where I is the moment of inertia and ω is the angular speed.

Solution:

1. For the solid sphere:

$$I_{\text{sphere}} = \frac{2}{5}mR^2$$

$$K_{\text{sphere}} = \frac{1}{2} \left(\frac{2}{5}mR^2 \right) \omega^2 = \frac{1}{5}mR^2\omega^2$$

2. For the solid cylinder:

$$I_{\text{cylinder}} = \frac{1}{2}mR^2$$

The angular speed is given as 2ω :

$$K_{\text{cylinder}} = \frac{1}{2} \left(\frac{1}{2}mR^2 \right) (2\omega)^2 = \frac{1}{4}mR^2(4\omega^2) = mR^2\omega^2$$

3. Find the ratio:

$$\frac{K_{\text{sphere}}}{K_{\text{cylinder}}} = \frac{\frac{1}{5}mR^2\omega^2}{mR^2\omega^2} = \frac{1}{5}$$

Final Answer: The ratio of their kinetic energies is 1 : 5.

Answer: (B)



Q9.

Solution**Concept:**

When an object is melted and recasted, its volume remains constant. The moment of inertia depends on the mass distribution relative to the axis.

Solution:

1. Volume of the disc (V_d):

$$V_d = \text{Area} \times \text{thickness} = \pi r^2 \times \frac{r}{6} = \frac{\pi r^3}{6}$$

2. Volume of the sphere (V_s):

$$V_s = \frac{4}{3}\pi R^3$$

3. Equating volumes ($V_d = V_s$):

$$\frac{\pi r^3}{6} = \frac{4}{3}\pi R^3 \implies \frac{r^3}{2} = 4R^3 \implies R^3 = \frac{r^3}{8} \implies R = \frac{r}{2}$$

4. Initial moment of inertia of disc (I):

$$I = \frac{1}{2}mr^2$$

5. Moment of inertia of sphere (I'):

$$I' = \frac{2}{5}mR^2 = \frac{2}{5}m\left(\frac{r}{2}\right)^2 = \frac{2}{5}m\frac{r^2}{4} = \frac{1}{10}mr^2$$

6. Relate I' to I :

$$I' = \frac{1}{5}\left(\frac{1}{2}mr^2\right) = \frac{I}{5}$$

Final Answer: The moment of inertia of the sphere is $I/5$.

Answer: (A)



Q10.

Solution**Concept:**Escape velocity (v_e) is given by:

$$v_e = \sqrt{\frac{2GM}{R}}$$

Substituting mass $M = \text{density}(\rho) \times \text{Volume} = \rho \times \frac{4}{3}\pi R^3$:

$$v_e = \sqrt{\frac{2G\rho \frac{4}{3}\pi R^3}{R}} = R\sqrt{\frac{8}{3}\pi G\rho}$$

Thus, for constant density, $v_e \propto R$.**Solution:**

1. Let v_E be the escape velocity of Earth and v_P be that of the planet. 2. Given $\rho_P = \rho_E$ and $R_P = 2R_E$. 3. Since v_e is directly proportional to R when density is constant:

$$\frac{v_P}{v_E} = \frac{R_P}{R_E} = \frac{2R_E}{R_E} = 2$$

4. Therefore, $v_P = 2 \times v_E$:

$$v_P = 2 \times 11.2 \text{ km/s} = 22.4 \text{ km/s}$$

Final Answer: The escape velocity from the planet is 22.4 km/s.**Answer: (B)**

Q11.

Solution**Concept:**

According to Kepler's Third Law (Law of Periods), the square of the time period of a satellite is proportional to the cube of the semi-major axis of its orbit ($T^2 \propto r^3$). For satellites in the same orbit, the orbital speed ($v = \sqrt{GM/r}$) and time period are independent of the mass of the satellite.

Solution:

1. Since both satellites S_1 and S_2 are in the same orbit, their distance r from the center of the Earth is the same. 2. The orbital speed v is given by:

$$v = \sqrt{\frac{GM}{r}}$$

Since G , M (mass of Earth), and r are constant for both, $v_1 = v_2$. 3. The time period T is given by:

$$T = \frac{2\pi r}{v}$$

Since r and v are the same for both, $T_1 = T_2$. 4. Potential Energy ($U = -GmM/r$) and Kinetic Energy ($K = \frac{1}{2}mv^2$) both depend on the mass m of the satellite. Since $m_1 = 4m_2$, their energies will be different. 5. Therefore, the only true statement is that they move with the same speed.

Final Answer: S_1 and S_2 are moving with the same speed.

Answer: (B)



Q12.

Solution**Concept:**

In a U-tube containing immiscible liquids, the pressure at the same horizontal level in a continuous static fluid must be equal. We choose the interface of the mercury and the liquids as the reference level.

Solution:

1. Let ρ_w be the density of water and ρ_s be the density of spirit. 2. At the interface level (the top of the mercury column), the pressure from the water column must equal the pressure from the spirit column.

$$P_{atm} + \rho_w g h_w = P_{atm} + \rho_s g h_s$$

3. Simplifying the equation:

$$\rho_w h_w = \rho_s h_s$$

4. Given $h_w = 10$ cm and $h_s = 12.5$ cm:

$$10\rho_w = 12.5\rho_s$$

5. Specific gravity is the ratio of the density of the substance to the density of water (ρ_s/ρ_w):

$$\text{Specific Gravity} = \frac{\rho_s}{\rho_w} = \frac{10}{12.5} = \frac{100}{125} = 0.8$$

Final Answer: The specific gravity of spirit is 0.8.

Answer: (A)



Q13.

Solution**Concept:**

When a ball reaches terminal velocity, the net force is zero, and the work done by the viscous force is converted into heat. The rate of heat production (dQ/dt) is equal to the power dissipated by the viscous force ($P = F_v \cdot v_t$).

Solution:

1. The viscous force F_v is given by Stokes' Law:

$$F_v = 6\pi\eta r v_t$$

2. The terminal velocity v_t is proportional to the square of the radius:

$$v_t = \frac{2r^2(\rho - \sigma)g}{9\eta} \implies v_t \propto r^2$$

3. The rate of heat production (Power) is:

$$\frac{dQ}{dt} = F_v \times v_t$$

4. Substitute the dependencies:

$$\frac{dQ}{dt} \propto (r \times v_t) \times v_t \propto r \times v_t^2$$

5. Since $v_t \propto r^2$, then $v_t^2 \propto r^4$:

$$\frac{dQ}{dt} \propto r \times r^4 = r^5$$

Final Answer: The rate of heat production is proportional to r^5 .

Answer: (C)



Q14.

Solution**Concept:**

If the difference in length between two rods is independent of temperature, it means both rods expand by the same amount for the same change in temperature ($\Delta L_1 = \Delta L_2$).

Solution:

1. The linear expansion formula is $\Delta L = L\alpha\Delta T$. 2. For the change in length to be independent of temperature change ΔT :

$$L_{Cu}\alpha_{Cu}\Delta T = L_{Al}\alpha_{Al}\Delta T$$

$$L_{Cu}\alpha_{Cu} = L_{Al}\alpha_{Al}$$

3. Substitute the given values ($L_{Cu} = 88$ cm, $\alpha_{Cu} = 1.7 \times 10^{-5}$, $\alpha_{Al} = 2.2 \times 10^{-5}$):

$$88 \times 1.7 \times 10^{-5} = L_{Al} \times 2.2 \times 10^{-5}$$

4. Solve for L_{Al} :

$$L_{Al} = \frac{88 \times 1.7}{2.2} = \frac{88}{2.2} \times 1.7$$

$$L_{Al} = 40 \times 1.7 = 68 \text{ cm}$$

Final Answer: The length of the aluminum rod is 68 cm.

Answer: (A)



Q15.

Solution**Concept:**

In an adiabatic process, the work done by the gas (W) is related to the change in internal energy (ΔU).

$$W = -\Delta U = -nC_v\Delta T = \frac{nR(T_i - T_f)}{\gamma - 1}$$

Solution:

1. Given $n = 1$, $W = 6R$, $T_i = T$, and $\gamma = 5/3$. 2. Use the formula for adiabatic work:

$$6R = \frac{1 \cdot R(T - T_f)}{\frac{5}{3} - 1}$$

3. Simplify the denominator:

$$\frac{5}{3} - 1 = \frac{2}{3}$$

4. Substitute back into the equation:

$$6R = \frac{R(T - T_f)}{2/3} = \frac{3R(T - T_f)}{2}$$

5. Divide both sides by R and solve for T_f :

$$6 = \frac{3(T - T_f)}{2} \implies 12 = 3(T - T_f)$$

$$4 = T - T_f \implies T_f = T - 4$$

Final Answer: The final temperature is $(T - 4)$ K.

Answer: (A)



Q16.

Solution**Concept:**

In a $P - V$ diagram, the work done in a cyclic process is equal to the area enclosed by the loop. If the cycle is clockwise, the net work done by the system is positive. If it is anti-clockwise, the net work done is negative.

Solution:

1. The process $ABCD$ forms a rectangle on the $P - V$ graph. 2. The change in volume (length of the rectangle) is:

$$\Delta V = V_B - V_A = 4V - V = 3V$$

3. The change in pressure (height of the rectangle) is:

$$\Delta P = P_A - P_D = 3P - P = 2P$$

4. The area of the rectangle represents the work done W :

$$W = \text{length} \times \text{height} = (3V) \times (2P)$$

$$W = 6PV$$

5. Since the cycle $A \rightarrow B \rightarrow C \rightarrow D \rightarrow A$ is clockwise, the work done is positive.

Final Answer: The net work done is $6PV$.

Answer: (B)



Q17.

Solution**Concept:**

The root mean square (rms) speed of gas molecules is given by the formula:

$$v_{rms} = \sqrt{\frac{3RT}{M}}$$

where T is the absolute temperature and M is the molar mass of the gas particles.

Solution:

1. Initial state: Diatomic gas with molar mass M at temperature T .

$$v = \sqrt{\frac{3RT}{M}}$$

2. Final state: The temperature is doubled ($T' = 2T$). The molecules dissociate into two atoms, meaning the new molar mass of the particles is half the original ($M' = M/2$). 3. Calculate the new rms speed v' :

$$v' = \sqrt{\frac{3R(2T)}{M/2}} = \sqrt{\frac{3R \cdot 2T \cdot 2}{M}}$$

$$v' = \sqrt{4 \cdot \frac{3RT}{M}} = 2\sqrt{\frac{3RT}{M}}$$

4. Substituting the initial velocity v :

$$v' = 2v$$

Final Answer: The new root mean square speed is $2v$.

Answer: (C)



Q18.

Solution**Concept:**

For a particle in Simple Harmonic Motion (SHM), the relationship between velocity (v), displacement (x), amplitude (A), and angular frequency (ω) is:

$$v^2 = \omega^2(A^2 - x^2)$$

Solution:

1. Write the equations for the two given positions:

$$v_1^2 = \omega^2(A^2 - x_1^2) \quad \text{--- (1)}$$

$$v_2^2 = \omega^2(A^2 - x_2^2) \quad \text{--- (2)}$$

2. Subtract equation (2) from equation (1):

$$v_1^2 - v_2^2 = \omega^2(A^2 - x_1^2) - \omega^2(A^2 - x_2^2)$$

$$v_1^2 - v_2^2 = \omega^2(x_2^2 - x_1^2)$$

3. Solve for ω :

$$\omega^2 = \frac{v_1^2 - v_2^2}{x_2^2 - x_1^2} \implies \omega = \sqrt{\frac{v_1^2 - v_2^2}{x_2^2 - x_1^2}}$$

4. The time period T is related to ω by $T = 2\pi/\omega$:

$$T = \frac{2\pi}{\sqrt{\frac{v_1^2 - v_2^2}{x_2^2 - x_1^2}}} = 2\pi \sqrt{\frac{x_2^2 - x_1^2}{v_1^2 - v_2^2}}$$

Final Answer: The time period is $2\pi \sqrt{\frac{x_2^2 - x_1^2}{v_1^2 - v_2^2}}$.

Answer: (B)



Q19.

Solution**Concept:**

The damping force F_d is proportional to the velocity v of the oscillator. This can be written as:

$$F_d = -bv$$

where b is the damping constant or the constant of proportionality.

Solution:

1. From the equation $F = bv$ (ignoring the negative sign for units), we have:

$$b = \frac{F}{v}$$

2. Substitute the SI units for Force and Velocity:

$$[b] = \frac{\text{Newton}}{\text{meter/second}} = \frac{\text{N}}{\text{m s}^{-1}}$$

3. Since $1 \text{ N} = 1 \text{ kg m s}^{-2}$:

$$[b] = \frac{\text{kg m s}^{-2}}{\text{m s}^{-1}}$$

4. Simplify the units:

$$[b] = \text{kg} \cdot \frac{\text{m}}{\text{m}} \cdot \frac{\text{s}^{-2}}{\text{s}^{-1}} = \text{kg s}^{-1}$$

Final Answer: The units of the constant are kg s^{-1} .

Answer: (A)



Q20.

Solution**Concept:**

Coulomb's Law states that the force between two point charges is:

$$F = k \frac{|q_1 q_2|}{r^2}$$

When charges are modified, the new force depends on the product of the new charges.

Solution:

1. Initial charges are $q_A = +Q$ and $q_B = -Q$. Initial force:

$$F = k \frac{Q^2}{r^2}$$

2. 25% of charge A is transferred. 25% of Q is $Q/4$. 3. New charge on A (q'_A):

$$q'_A = Q - \frac{Q}{4} = \frac{3Q}{4}$$

4. New charge on B (q'_B):

$$q'_B = -Q + \frac{Q}{4} = -\frac{3Q}{4}$$

5. The new force F' is:

$$F' = k \frac{|q'_A q'_B|}{r^2} = k \frac{(3Q/4)(3Q/4)}{r^2}$$

$$F' = \frac{9}{16} \left(k \frac{Q^2}{r^2} \right) = \frac{9}{16} F$$

Final Answer: The force becomes $9F/16$.

Answer: (B)



Q21.

Solution**Concept:**

When a capacitor is filled with slabs of different dielectrics of different thicknesses, it can be treated as a series combination of capacitors. The equivalent capacitance C_{eq} is given by:

$$\frac{1}{C_{eq}} = \frac{1}{C_1} + \frac{1}{C_2}$$

The capacitance of a plate filled with dielectric K and thickness t is $C = \frac{K\epsilon_0 A}{t}$.

Solution:

1. Initial capacitance $C_0 = \frac{\epsilon_0 A}{d} = 9 \text{ pF}$. 2. The capacitor is now divided into two parts in series: - C_1 with $K_1 = 3$ and $t_1 = d/3$:

$$C_1 = \frac{3\epsilon_0 A}{d/3} = 9 \frac{\epsilon_0 A}{d} = 9C_0$$

- C_2 with $K_2 = 6$ and $t_2 = 2d/3$:

$$C_2 = \frac{6\epsilon_0 A}{2d/3} = \frac{18\epsilon_0 A}{2d} = 9 \frac{\epsilon_0 A}{d} = 9C_0$$

3. Since $C_1 = 9C_0$ and $C_2 = 9C_0$ are in series:

$$C_{new} = \frac{C_1 \cdot C_2}{C_1 + C_2} = \frac{9C_0 \cdot 9C_0}{9C_0 + 9C_0} = \frac{81C_0^2}{18C_0} = 4.5C_0$$

4. Calculate final value:

$$C_{new} = 4.5 \times 9 \text{ pF} = 40.5 \text{ pF}$$

Final Answer: The capacitance is 40.5 pF.

Answer: (C)



Q22.

Solution**Concept:**

For a uniformly charged spherical conductor, the electric field at a point outside the sphere ($r > R$) is calculated as if all the charge were concentrated at the center. The formula is:

$$E = \frac{1}{4\pi\epsilon_0} \frac{q}{r^2}$$

Solution:

1. Given values: - $q = 3.2 \times 10^{-7} \text{ C}$ - $r = 15 \text{ cm} = 0.15 \text{ m}$ - $k = 9 \times 10^9 \text{ Nm}^2/\text{C}^2$ 2. Substitute into the formula:

$$E = \frac{9 \times 10^9 \times 3.2 \times 10^{-7}}{(0.15)^2}$$

3. Simplify the numerator and denominator:

$$E = \frac{28.8 \times 10^2}{0.0225}$$

4. Calculate the final value:

$$E = \frac{2880}{0.0225} = 1.28 \times 10^5 \text{ N/C}$$

Final Answer: The magnitude of electric field is $1.28 \times 10^5 \text{ N/C}$.

Answer: (B)



Q23.

Solution**Concept:**

A potentiometer works on the principle that the potential drop across any length of the wire is directly proportional to its length ($V \propto l$), provided the current and resistance per unit length are constant.

$$\frac{E_1}{E_2} = \frac{l_1}{l_2}$$

Solution:

1. Given: - $E_1 = 1.5 \text{ V}$, $l_1 = 36 \text{ cm}$ - $E_2 = 2.5 \text{ V}$, $l_2 = ?$ 2. Using the ratio formula:

$$\frac{1.5}{2.5} = \frac{36}{l_2}$$

3. Rearrange to solve for l_2 :

$$l_2 = 36 \times \frac{2.5}{1.5}$$

4. Simplify the fraction ($2.5/1.5 = 5/3$):

$$l_2 = 36 \times \frac{5}{3}$$

$$l_2 = 12 \times 5 = 60 \text{ cm}$$

Final Answer: The balance point will occur at 60 cm.

Answer: (A)

Q24.

Solution**Concept:**

When a wire is stretched, its volume remains constant. Resistance is given by $R = \rho \frac{L}{A}$. As length (L) increases, the cross-sectional area (A) must decrease to keep Volume ($V = A \times L$) constant.

Solution:

1. Initial resistance: $R = \rho \frac{L}{A}$. 2. New length $L' = nL$. 3. Since Volume $V = A \cdot L = A' \cdot L'$:

$$A' = \frac{A \cdot L}{L'} = \frac{A \cdot L}{nL} = \frac{A}{n}$$

4. New resistance R' :

$$R' = \rho \frac{L'}{A'} = \rho \frac{nL}{A/n}$$

$$R' = n^2 \left(\rho \frac{L}{A} \right)$$

5. Therefore, $R' = n^2 R$.

Final Answer: The new resistance will be $n^2 R$.

Answer: (C)



Q25.

Solution**Concept:**

To find the total current, first find the equivalent resistance (R_{eq}) of the entire network. Then apply Ohm's Law ($I = V/R_{eq}$).

Solution:

1. Identify the components: $R_1 = 2\Omega$ and $R_2 = 4\Omega$ are in parallel. 2. Equivalent resistance of the parallel part (R_p):

$$\frac{1}{R_p} = \frac{1}{2} + \frac{1}{4} = \frac{2+1}{4} = \frac{3}{4} \implies R_p = \frac{4}{3}\Omega \approx 1.33\Omega$$

3. This parallel combination is in series with $R_3 = 1\Omega$ and $R_4 = 5\Omega$. 4. Total Equivalent Resistance (R_{eq}):

$$R_{eq} = R_p + R_3 + R_4 = 1.33 + 1 + 5 = 7.33\Omega$$

5. Total current (I) using $V = 12\text{ V}$:

$$I = \frac{V}{R_{eq}} = \frac{12}{7.33} \approx 1.637\text{ A}$$

6. Rounding to the nearest option: 1.65 A.

Final Answer: The total current is 1.65 A.

Answer: (A)



Q26.

Solution**Concept:**

Self-inductance (L) is the property of a coil that opposes the change in current. The total magnetic flux (Φ_{total}) linked with a solenoid is proportional to the current (I) flowing through it:

$$\Phi_{total} = N\phi = LI$$

where N is the number of turns and ϕ is the flux through a single turn.

Solution:

1. Given: - $N = 1000$ - $\phi = 4 \times 10^{-3}$ Wb - $I = 4$ A 2. Calculate the total flux:

$$\Phi_{total} = N\phi = 1000 \times 4 \times 10^{-3} = 4 \text{ Wb}$$

3. Use the relation $\Phi_{total} = LI$:

$$4 = L \times 4$$

4. Solve for L :

$$L = \frac{4}{4} = 1 \text{ H}$$

Final Answer: The self-inductance is 1 H.

Answer: (D)

Q27.

Solution**Concept:**

The magnetic force ($\vec{F} = q(\vec{v} \times \vec{B})$) acting on a charged particle is always perpendicular to its velocity. Since the force is perpendicular to the displacement, the work done by the magnetic field is zero.

Solution:

1. Since work done $W = 0$, by the Work-Energy Theorem, the change in kinetic energy $\Delta K = 0$. Thus, kinetic energy remains constant. 2. Speed (v) is constant because kinetic energy ($1/2mv^2$) is constant. 3. However, the magnetic force acts as a centripetal force, constantly changing the direction of the velocity vector. 4. Momentum ($\vec{p} = m\vec{v}$) is a vector quantity. Even if the magnitude (speed) is constant, the change in direction means the momentum vector is changing.

Final Answer: The momentum changes but the kinetic energy is constant.

Answer: (A)



Q28.

Solution**Concept:**

According to Faraday's Law of Induction, the average induced EMF (e) is given by the rate of change of magnetic flux:

$$e = -N \frac{\Delta\Phi}{\Delta t} = -N \frac{\Phi_f - \Phi_i}{\Delta t}$$

where $\Phi = BA \cos \theta$.

Solution:

1. Initial flux ($\theta = 0^\circ$): $\Phi_i = B_H A$. 2. Final flux after 180° rotation ($\theta = 180^\circ$): $\Phi_f = B_H A \cos(180^\circ) = -B_H A$. 3. Change in flux: $\Delta\Phi = \Phi_f - \Phi_i = -B_H A - B_H A = -2B_H A$. 4. Calculate area $A = \pi r^2$:

$$A = \pi(0.1)^2 = 0.01\pi \text{ m}^2$$

5. Calculate EMF magnitude:

$$|e| = N \frac{2B_H A}{\Delta t} = 500 \times \frac{2 \times 3 \times 10^{-5} \times 0.01\pi}{0.25}$$

6. Simplify:

$$|e| = \frac{1000 \times 3 \times 10^{-5} \times 0.0314}{0.25} = \frac{3 \times 10^{-2} \times 0.0314}{0.25}$$

$$|e| = \frac{0.000942}{0.25} \approx 3.768 \times 10^{-3} \text{ V}$$

7. Rounding gives $3.8 \times 10^{-3} \text{ V}$.

Final Answer: The induced EMF is $3.8 \times 10^{-3} \text{ V}$.

Answer: (A)

Q29.

Solution**Concept:**

Magnetic susceptibility (χ_m) measures how a material responds to an external magnetic field. It is defined by $M = \chi_m H$.

Solution:

1. Diamagnetic materials create an induced magnetic field in a direction opposite to the external magnetic field. This means they are weakly repelled. Consequently, their susceptibility χ_m is negative. 2. Paramagnetic materials have a small positive susceptibility. 3. Ferromagnetic materials have a large positive susceptibility. 4. Therefore, a negative value is a unique characteristic of diamagnetism.

Final Answer: The magnetic susceptibility is negative for diamagnetic materials only.

Answer: (B)



Q30.

Solution**Concept:**

The magnetic force on a curved wire in a uniform magnetic field is equal to the force on a straight wire connecting the two endpoints of the curve.

$$\vec{F} = I(\vec{L}_{eff} \times \vec{B})$$

where \vec{L}_{eff} is the vector displacement from the start point to the end point.

Solution:

1. For a semi-circle of radius R , the starting point is at $(-R, 0)$ and the end point is at $(R, 0)$ (assuming the center at origin). 2. The effective length vector \vec{L}_{eff} is the straight line distance between the ends:

$$L_{eff} = 2R \text{ (along the x-axis)}$$

3. The magnetic field B is along the z -axis (perpendicular to the wire's plane). 4. The magnitude of the force is:

$$F = I \cdot L_{eff} \cdot B \sin(90^\circ) = I(2R)B$$

$$F = 2IRB$$

Final Answer: The magnitude of the magnetic force is $2IRB$.

Answer: (A)



Q31.

Solution**Concept:**

The phase difference ϕ in an LCR circuit is given by $\tan \phi = \frac{|X_L - X_C|}{R}$. The power factor is $\cos \phi$.

Solution:

1. Case 1: L is removed. The circuit is RC .

$$\tan(\pi/3) = \frac{X_C}{R} \implies \sqrt{3} = \frac{X_C}{R} \implies X_C = R\sqrt{3}$$

2. Case 2: C is removed. The circuit is LR .

$$\tan(\pi/3) = \frac{X_L}{R} \implies \sqrt{3} = \frac{X_L}{R} \implies X_L = R\sqrt{3}$$

3. In the original LCR circuit, since $X_L = X_C$, the circuit is in resonance. 4. For resonance, the net reactance $X = X_L - X_C = 0$. 5. The phase difference ϕ becomes 0:

$$\tan \phi = \frac{0}{R} = 0 \implies \phi = 0$$

6. Power factor = $\cos \phi = \cos(0) = 1$.

Final Answer: The power factor is 1.0.

Answer: (B)

Q32.

Solution**Concept:**

In an electromagnetic wave traveling in a vacuum, the ratio of the amplitude of the electric field (E_0) to the amplitude of the magnetic field (B_0) is equal to the speed of light (c).

$$c = \frac{E_0}{B_0}$$

Solution:

1. Given $E_0 = 48$ V/m and $c = 3 \times 10^8$ m/s. 2. Rearrange the formula to solve for B_0 :

$$B_0 = \frac{E_0}{c}$$

3. Substitute the values:

$$B_0 = \frac{48}{3 \times 10^8}$$

4. Perform the division:

$$B_0 = 16 \times 10^{-8} \text{ T} = 1.6 \times 10^{-7} \text{ T}$$

Final Answer: The amplitude of the magnetic field is 1.6×10^{-7} T.

Answer: (A)



Q33.

Solution**Concept:**

For light passing through a prism, the relations are $r_1 + r_2 = A$ and $\mu = \frac{\sin i}{\sin r_1}$. If a ray emerges normally, the angle of emergence $e = 0$.

Solution:

1. Emerges normally means $e = 0$, which implies the angle of refraction at the second face $r_2 = 0$.
2. Using $r_1 + r_2 = A$:

$$r_1 + 0 = A \implies r_1 = A$$

3. Apply Snell's Law at the first face:

$$\mu = \frac{\sin i}{\sin r_1} = \frac{\sin i}{\sin A}$$

4. For small angles, $\sin \theta \approx \theta$ (in radians):

$$\mu \approx \frac{i}{A}$$

5. Solving for i :

$$i = \mu A$$

Final Answer: The angle of incidence is nearly equal to μA .

Answer: (C)



Q34.

Solution**Concept:**

The mirror formula is $\frac{1}{f} = \frac{1}{v} + \frac{1}{u}$. We calculate the image position v for two different object positions u_1 and u_2 .

Solution:

1. Initial state: $f = -15$ cm, $u_1 = -40$ cm.

$$\frac{1}{-15} = \frac{1}{v_1} + \frac{1}{-40} \implies \frac{1}{v_1} = \frac{1}{40} - \frac{1}{15} = \frac{3-8}{120} = -\frac{5}{120}$$

$$v_1 = -24 \text{ cm}$$

2. Final state: Object moves 20 cm towards mirror. New $u_2 = -40 + 20 = -20$ cm.

$$\frac{1}{-15} = \frac{1}{v_2} + \frac{1}{-20} \implies \frac{1}{v_2} = \frac{1}{20} - \frac{1}{15} = \frac{3-4}{60} = -\frac{1}{60}$$

$$v_2 = -60 \text{ cm}$$

3. Displacement of image:

$$\Delta v = |v_2| - |v_1| = 60 - 24 = 36 \text{ cm}$$

4. Since v changed from -24 to -60 , the image moved further away from the mirror.

Final Answer: The image displacement is 36 cm away from the mirror.

Answer: (B)

Q35.

Solution**Concept:**

Lens Maker's formula: $\frac{1}{f} = (\mu - 1) \left(\frac{1}{R_1} - \frac{1}{R_2} \right)$. Power $P = 1/f$.

Solution:

1. For a biconvex lens with radii R and $-R$:

$$P = (\mu - 1) \left(\frac{1}{R} - \frac{1}{-R} \right) = (\mu - 1) \left(\frac{2}{R} \right)$$

2. When cut vertically, we get two plano-convex lenses. For one such lens, $R_1 = R$ and $R_2 = \infty$. 3. New Power P' :

$$P' = (\mu - 1) \left(\frac{1}{R} - \frac{1}{\infty} \right) = (\mu - 1) \left(\frac{1}{R} \right)$$

4. Comparing P and P' :

$$P' = \frac{P}{2}$$

Final Answer: The power of each resulting lens is $P/2$.

Answer: (C)



Q36.

Solution**Concept:**

The intensity I at any point where the phase difference is ϕ is given by:

$$I = I_{max} \cos^2 \left(\frac{\phi}{2} \right)$$

The relationship between phase difference (ϕ) and path difference (Δx) is:

$$\phi = \frac{2\pi}{\lambda} \Delta x$$

Solution:

1. Given the path difference $\Delta x = \frac{\lambda}{8}$. 2. Calculate the phase difference:

$$\phi = \frac{2\pi}{\lambda} \left(\frac{\lambda}{8} \right) = \frac{\pi}{4}$$

3. Substitute the phase difference into the intensity formula:

$$I = I_{max} \cos^2 \left(\frac{\pi/4}{2} \right) = I_{max} \cos^2 \left(\frac{\pi}{8} \right)$$

4. Use the identity $\cos^2 \theta = \frac{1+\cos 2\theta}{2}$:

$$\frac{I}{I_{max}} = \frac{1 + \cos(\pi/4)}{2} = \frac{1 + \frac{1}{\sqrt{2}}}{2}$$

5. Simplify the expression ($\frac{1}{\sqrt{2}} \approx 0.707$):

$$\frac{I}{I_{max}} = \frac{1 + 0.707}{2} = \frac{1.707}{2} = 0.8535$$

Final Answer: The ratio is 0.853.

Answer: (A)



Q37.

Solution**Concept:**

Einstein's photoelectric equation relates the energy of incident photons to the work function and the maximum kinetic energy (stopping potential V_s):

$$h\nu = h\nu_0 + eV_s \implies eV_s = h(\nu - \nu_0)$$

Solution:

1. Given: $\nu = 8.2 \times 10^{14} \text{ Hz}$ - $\nu_0 = 3.3 \times 10^{14} \text{ Hz}$ - $h \approx 6.63 \times 10^{-34} \text{ Js}$ 2. Calculate the frequency difference:

$$\Delta\nu = \nu - \nu_0 = (8.2 - 3.3) \times 10^{14} = 4.9 \times 10^{14} \text{ Hz}$$

3. Use the energy equation:

$$eV_s = (6.63 \times 10^{-34}) \times (4.9 \times 10^{14})$$

$$eV_s \approx 32.48 \times 10^{-20} \text{ J}$$

4. Convert energy to electron-volts by dividing by $e = 1.6 \times 10^{-19} \text{ C}$:

$$V_s = \frac{32.48 \times 10^{-20}}{1.6 \times 10^{-19}} = \frac{3.248}{1.6} \approx 2.03 \text{ V}$$

Final Answer: The cutoff voltage is nearly 2 V.

Answer: (A)



Q38.

Solution**Concept:**

The de Broglie wavelength λ of an electron accelerated through a potential V is given by the approximation:

$$\lambda = \frac{1.227}{\sqrt{V}} \text{ nm}$$

Solution:

1. Given $\lambda = 1.227 \times 10^{-2}$ nm. 2. Substitute into the formula:

$$1.227 \times 10^{-2} = \frac{1.227}{\sqrt{V}}$$

3. Simplify and solve for \sqrt{V} :

$$10^{-2} = \frac{1}{\sqrt{V}}$$

$$\sqrt{V} = \frac{1}{10^{-2}} = 100$$

4. Square both sides:

$$V = (100)^2 = 10,000 \text{ V} = 10^4 \text{ V}$$

Final Answer: The potential difference is 10^4 V.

Answer: (D)



Q39.

Solution**Concept:**

The wavelength λ of spectral lines is given by the Rydberg formula:

$$\frac{1}{\lambda} = R \left(\frac{1}{n_1^2} - \frac{1}{n_2^2} \right)$$

The "last line" of a series (series limit) occurs when $n_2 = \infty$.

Solution:

1. For Lyman series, $n_1 = 1$. Last line ($n_2 = \infty$):

$$\frac{1}{\lambda_L} = R \left(\frac{1}{1^2} - \frac{1}{\infty} \right) = R \implies \lambda_L = \frac{1}{R}$$

2. For Balmer series, $n_1 = 2$. Last line ($n_2 = \infty$):

$$\frac{1}{\lambda_B} = R \left(\frac{1}{2^2} - \frac{1}{\infty} \right) = \frac{R}{4} \implies \lambda_B = \frac{4}{R}$$

3. Find the ratio:

$$\frac{\lambda_B}{\lambda_L} = \frac{4/R}{1/R} = 4$$

Final Answer: The ratio is 4.

Answer: (B)

Q40.

Solution**Concept:**

Einstein's photoelectric equation in terms of stopping potential V_0 is:

$$V_0 = \left(\frac{h}{e} \right) \nu - \frac{\Phi_0}{e}$$

This is a linear equation $y = mx + c$, where the slope is h/e (constant for all materials) and the x-intercept is the threshold frequency ν_0 . Work function $\Phi_0 = h\nu_0$.

Solution:

1. From the graph, material B has a higher threshold frequency than material A ($\nu_{0B} > \nu_{0A}$). 2. Since $\Phi_0 \propto \nu_0$, the work function of B must be greater than the work function of A . 3. The slopes of both curves are equal to h/e , so the statement about different slopes is incorrect. 4. Therefore, the correct conclusion is that B has a greater work function.

Final Answer: Work function of B is greater than A .

Answer: (B)



Q41.

Solution**Concept:**

The amount of radioactive substance remaining is given by $N = N_0 e^{-\lambda t}$ or $N = N_0 (1/2)^n$, where n is the number of half-lives.

Solution:

1. At 40% decay, the amount remaining is $N_1 = 60\%N_0 = 0.6N_0$. 2. At 85% decay, the amount remaining is $N_2 = 15\%N_0 = 0.15N_0$. 3. We need to find the time interval Δt between these two states:

$$\frac{N_2}{N_1} = \frac{0.15N_0}{0.6N_0} = \frac{1}{4} = \left(\frac{1}{2}\right)^2$$

4. Since $\frac{N_2}{N_1} = (1/2)^n$, where n is the number of half-lives elapsed during this interval, we see $n = 2$. 5. Time taken $\Delta t = n \times T_{1/2} = 2 \times 30$ minutes = 60 minutes.

Final Answer: The time taken is 60 minutes.

Answer: (D)

Q42.

Solution**Concept:**

In a CE amplifier, the voltage gain A_v is given by:

$$A_v = \frac{V_{out}}{V_{in}} = \beta \frac{R_C}{R_B}$$

where β is current gain, R_C is collector resistance, and R_B is base resistance.

Solution:

1. Given: $V_{out} = 2$ V, $R_C = 2000\Omega$, $R_B = 1000\Omega$, and $\beta = 100$. 2. First, calculate the voltage gain:

$$A_v = 100 \times \frac{2000}{1000} = 100 \times 2 = 200$$

3. Now, find V_{in} using $V_{out} = A_v \times V_{in}$:

$$2 = 200 \times V_{in}$$

4. Solve for V_{in} :

$$V_{in} = \frac{2}{200} = 0.01 \text{ V}$$

5. Convert to millivolts:

$$0.01 \text{ V} = 10 \text{ mV}$$

Final Answer: The input signal voltage is 10 mV.

Answer: (A)



Q43.

Solution**Concept:**

A NAND gate followed by another NAND gate with tied inputs (acting as a NOT gate) results in an AND operation.

$$\text{Output of first gate} = \overline{A \cdot B}$$

$$\text{Output of second gate} = \overline{\overline{A \cdot B}} = A \cdot B$$

Solution:

1. The first gate is a NAND gate with inputs A and B . Its output is $X = \overline{A \cdot B}$. 2. The second gate has both its inputs connected to X . The output of a NAND gate with identical inputs X is $\overline{X \cdot X} = \overline{X}$, which is the NOT operation. 3. Therefore, the final output Y is:

$$Y = \text{NOT}(X) = \text{NOT}(\text{NAND}(A, B))$$

$$Y = \overline{\overline{A \cdot B}} = A \cdot B$$

4. This logic configuration represents an AND gate.

Final Answer: The output is $A \cdot B$.

Answer: (A)

Q44.

Solution**Concept:**

The properties of semiconductors are highly temperature-dependent. Heating increases the number of minority charge carriers due to thermal excitation across the energy gap.

Solution:

1. In a $p - n$ junction, the leakage current (reverse saturation current) is highly sensitive to temperature. 2. The forward bias current also changes because the barrier potential decreases as temperature increases. 3. Since both forward and reverse currents are modified, the entire current-voltage ($V - I$) characteristic curve shifts. 4. Therefore, heating affects the overall $V - I$ characteristics of the diode.

Final Answer: It affects the overall $V - I$ characteristics.

Answer: (C)



Q45.

Solution**Concept:**

For the final image to coincide with the object, the light rays must retrace their path. This happens if the rays strike the convex mirror normally (perpendicularly). Light rays strike a mirror normally if they are directed towards its center of curvature (C).

Solution:

1. The lens forms an image at position v . For the rays to be normal to the mirror, this image must be at the center of curvature of the mirror. 2. Calculate v using the lens formula:

$$\frac{1}{f_L} = \frac{1}{v} - \frac{1}{u} \implies \frac{1}{v} = \frac{1}{f_L} + \frac{1}{-a} = \frac{a - f_L}{af_L}$$

$$v = \frac{af_L}{a - f_L}$$

3. This image distance v is measured from the lens. The mirror is at distance d from the lens. 4. The distance from the mirror to the center of curvature (R) is:

$$R = v - d = \frac{af_L}{a - f_L} - d$$

5. The focal length of the mirror f_m is $R/2$:

$$f_m = \frac{1}{2} \left[\frac{af_L}{a - f_L} - d \right]$$

Final Answer: $f_m = \frac{1}{2} \left[\frac{af_L}{a - f_L} - d \right]$.

Answer: (B)



Answer Key

Q	Ans	Q	Ans	Q	Ans	Q	Ans	Q	Ans
1	A	2	C	3	B	4	A	5	B
6	C	7	B	8	B	9	A	10	B
11	B	12	A	13	C	14	A	15	A
16	B	17	C	18	B	19	A	20	B
21	C	22	B	23	A	24	C	25	A
26	D	27	A	28	A	29	B	30	A
31	B	32	A	33	C	34	B	35	C
36	A	37	A	38	D	39	B	40	B
41	D	42	A	43	A	44	C	45	B

