



Class 12 Physics Chapterwise PYQs

2026 – 2003 | All CBSE Board Papers

Chapter-wise previous year questions, sorted by marks and year

Chapter 12: Atoms

Table of Contents

- | | |
|--------------------|--------------------------------|
| • 1-Mark Questions | 52 questions • Section A • MCQ |
| • 2-Mark Questions | 47 questions • Section B • VSA |
| • 3-Mark Questions | 64 questions • Section C • SA |

1-Mark Questions (52 questions · Section A · MCQ)

- Q1.** Two statements are given - one labelled as Assertion (A) and the other labelled as Reason (R). Select the correct answer from the options below: (A) Both Assertion (A) and Reason (R) are true and Reason (R) is the correct explanation of the Assertion (A). (B) Both Assertion (A) and Reason (R) are true, but Reason (R) is not the correct explanation of the Assertion (A). (C) Assertion (A) is true, but Reason (R) is false. (D) Both Assertion (A) and Reason (R) are false. Assertion (A): In Bohr model of hydrogen atom, the energy levels are discrete and quantised. Reason (R): In a hydrogen atom, the electrostatic force on the electron provides the necessary centripetal force to it to revolve around the nucleus.
- (A) Both Assertion (A) and Reason (R) are true and Reason (R) is the correct explanation of (A).
- (B) Both Assertion (A) and Reason (R) are true, but Reason (R) is not the correct explanation of (A).
- (C) Assertion (A) is true, but Reason (R) is false.
- (D) Both Assertion (A) and Reason (R) are false.
- [2026 • Set 55-1-1]**
- Q2.** The 'distance of closest approach' of an alpha-particle is ' d ' when it moves with a velocity v head-on towards the target nucleus. If the velocity of alpha particle is halved, the new 'distance of closest approach' will be:

- (A) $\frac{d}{2}$
- (B) $2d$
- (C) $\frac{d}{4}$
- (D) $4d$

[2026 • Set 55-1-1]

Q3. The distance-of-closest-approach for an alpha particle is ' d ' when it moves head-on with speed v towards a target nucleus. If the alpha particle is replaced by a proton moving with the same speed, the new distance-of-closest-approach will be:

- (A) $2d$
- (B) d
- (C) $\frac{d}{2}$
- (D) $\frac{d}{4}$

[2026 • Set 55-1-2]

Q4. The ratio of the potential energy to the kinetic energy of an electron in n^{th} orbit of Bohr model of hydrogen atom is:

- (A) $-\frac{1}{2}$
- (B) $\frac{1}{2}$
- (C) 2
- (D) -2

[2026 • Set 55-1-3]

Q5. In Bohr model of hydrogen atom, the electron makes a transition from $n = 5$ to $n = 1$ state. As a result, a photon of wavelength λ is emitted in the process. The wavelength of the photon emitted when an electron makes a transition from energy level $n = 5$ to $n = 2$ will be:

- (A) $\frac{8}{7}\lambda$
- (B) $\frac{24}{7}\lambda$
- (C) $\frac{16}{7}\lambda$
- (D) $\frac{32}{7}\lambda$

[2026 • Set 55-2-1]

Q6. In Bohr model of hydrogen atom, for large values of n , the distance between the consecutive orbits is proportional to:

- (A) \sqrt{n}
- (B) n

- (C) n^2
- (D) n^3

[2026 • Set 55-2-1]

Q7. In Bohr model of hydrogen atom, the value of potential energy of an electron in n^{th} orbit varies with n as:

- (A) $\frac{1}{n^2}$
- (B) $\frac{1}{n}$
- (C) n
- (D) n^2

[2026 • Set 55-2-2]

Q8. In Bohr model of hydrogen atom, an electron makes a transition from $n = 4$ state to $n = 1$ state and a photon of frequency ν is emitted. The frequency of photon emitted when an electron makes a transition from $n = 4$ state to $n = 2$ state in the same model is:

- (A) $\frac{\nu}{3}$
- (B) $\frac{\nu}{5}$
- (C) $\frac{\nu}{4}$
- (D) $\frac{\nu}{2}$

[2026 • Set 55-2-2]

Q9. According to Bohr model of hydrogen atom, the time period of an electron in its n^{th} orbit is proportional to:

- (A) n
- (B) n^2
- (C) n^3
- (D) n^4

[2026 • Set 55-2-3]

Q10. In Bohr model of hydrogen atom, an electron is moving in an orbit, with total energy -3.4 eV. Its angular momentum will be:

- (A) 1.05×10^{-34} J s
- (B) 6.63×10^{-34} J s
- (C) 3.31×10^{-34} J s
- (D) 2.1×10^{-34} J s

[2026 • Set 55-2-3]

Q11. The ratio of the de Broglie wavelengths associated with the electron revolving in the first and third orbits in hydrogen atom is:

- (A) 2
- (B) $\frac{1}{3}$
- (C) $\frac{3}{3}$
- (D) $\frac{3}{2}$

[2026 • Set 55-3-3]

Q12. The energy of an electron in an orbit in hydrogen atom is -3.4 eV. Its angular momentum in the orbit will be:

- (A) $\frac{3h}{2\pi}$
- (B) $\frac{2h}{\pi}$
- (C) $\frac{h}{\pi}$
- (D) $\frac{h}{2\pi}$

[2026 • Set 55-5-1]

Q13. The energy of an electron revolving in the n th orbit in Bohr model of hydrogen atom is proportional to:

- (A) n^2
- (B) n
- (C) $\frac{1}{n}$
- (D) $\frac{1}{n^2}$

[2026 • Set 55-5-2]

Q14. Assertion (A): The potential energy of an electron revolving in any stationary orbit in a hydrogen atom is positive. Reason (R): The total energy of a charged particle is always positive.

- (A) Both Assertion (A) and Reason (R) are true and Reason (R) is the correct explanation of Assertion (A).
- (B) Both Assertion (A) and Reason (R) are true, but Reason (R) is not the correct explanation of Assertion (A).
- (C) Assertion (A) is true, but Reason (R) is false.
- (D) Assertion (A) is false and Reason (R) is also false.

[2025 • Set 55-1-1]

Q15. The energy of an electron in a hydrogen atom in ground state is -13.6 eV. Its energy in an orbit corresponding to quantum number n is -0.544 eV. The value of n is

- (A) 2
- (B) 3
- (C) 4

(D) 5

[2025 • Set 55-2-1]

Q16. Assertion (A): In Bohr model of hydrogen atom, the angular momentum of an electron in n^{th} orbit is proportional to the square root of its orbit radius r_n . Reason (R): According to Bohr model, electron can jump to its nearest orbits only.

- (A) Both Assertion (A) and Reason (R) are true and Reason (R) is the correct explanation of Assertion (A).
(B) Both Assertion (A) and Reason (R) are true but Reason (R) is not the correct explanation of Assertion (A).
(C) Assertion (A) is true but Reason (R) is false.
(D) Both Assertion (A) and Reason (R) are false.

[2025 • Set 55-2-1]

Q17. A body acquires charge 8.0×10^{-12} C. The mass of the body :

- (A) increases by 4.5×10^{-7} kg
(B) decreases by 1.0×10^{-8} kg
(C) decreases by 4.55×10^{-23} kg
(D) increases by 9.1×10^{-23} kg

[2025 • Set 55-4-1]

Q18. Case Study (Q30): A hydrogen atom consists of an electron revolving in a circular orbit of radius r with certain velocity v around a proton located at the nucleus of the atom. The electrostatic force of attraction between the revolving electron and the proton provides the requisite centripetal force to keep it in the orbit. According to Bohr's model, an electron can revolve only in certain stable orbits. The angular momentum of the electron in these orbits is some integral multiple of $\frac{h}{2\pi}$, where h is the Planck's constant. Further, when an electron makes a transition from one orbit of higher energy to that of lower energy, a photon is emitted having energy equal to the difference between energies of the initial and final states. Assuming the mass and charge of an electron as m and e respectively, answer the following questions. (i) The expression for the speed of electron v in terms of radius of the orbit (r) and physical constant $\left(K = \frac{1}{4\pi\epsilon_0}\right)$ is :

- (A) $\frac{Ke^2}{mr}$
(B) $\frac{Ke^2}{mr^2}$
(C) $\sqrt{\frac{Ke^2}{mr}}$
(D) $\sqrt{\frac{Ke^2}{mr^2}}$

[2025 • Set 55-4-1]

Q19. (ii) The total energy of the atom in terms of r and physical constant K is :

- (A) $\frac{Ke^2}{r}$
- (B) $-\frac{Ke^2}{2r}$
- (C) $\frac{Ke^2}{2r}$
- (D) $-\frac{3Ke^2}{2r}$

[2025 • Set 55-4-1]

Q20. (iii) A photon of wavelength 500 nm is emitted when an electron makes a transition from one state to the other state in an atom. The change in the total energy of the electron and change in its kinetic energy in eV as per Bohr's model, respectively will be :

- (A) 2.48, -2.48
- (B) -1.24, 1.24
- (C) -2.48, 2.48
- (D) 1.24, -1.24

[2025 • Set 55-4-1]

Q21. (iv) OR: An electron makes a transition from -3.4 eV state to the ground state in hydrogen atom. Its radius of orbit changes by : (radius of orbit of electron in ground state = 0.53 \AA)

- (A) 0.53 \AA
- (B) 1.06 \AA
- (C) 1.59 \AA
- (D) 2.12 \AA

[2025 • Set 55-4-1]

Q22. Assertion (A): The Balmer series in hydrogen atom spectrum is formed when the electron jumps from higher energy state to the ground state. Reason (R): In Bohr's model of hydrogen atom, the electron can jump between successive orbits only.

- (A) Both Assertion (A) and Reason (R) are true and Reason (R) is the correct explanation of the Assertion (A).
- (B) Both Assertion (A) and Reason (R) are true, but Reason (R) is not the correct explanation of the Assertion (A).
- (C) Assertion (A) is true, but Reason (R) is false.
- (D) Both Assertion (A) and Reason (R) are false.

[2025 • Set 55-5-1]

Q23. Assertion (A): In Rutherford's alpha particle scattering experiment, the presence of only few alpha particles at angle of scattering π led him to the discovery of nucleus. Reason (R): The size of nucleus is approximately 10^{-4} times the size of an atom and therefore

only few alpha particles are rebounded.

- (A) Both Assertion (A) and Reason (R) are true and Reason (R) is the correct explanation of the Assertion (A).
- (B) Both Assertion (A) and Reason (R) are true, but Reason (R) is not the correct explanation of the Assertion (A).
- (C) Assertion (A) is true, but Reason (R) is false.
- (D) Both Assertion (A) and Reason (R) are false.

[2025 • Set 55-5-1]

Q24. Assertion (A): X-rays are produced when slow moving electrons are stopped by a metal target of high atomic number. Reason (R): X-rays consist of low-energy photons. Select the correct answer from the codes given below:

- (A) Both Assertion (A) and Reason (R) are true and Reason (R) is the correct explanation of Assertion (A).
- (B) Both Assertion (A) and Reason (R) are true, but Reason (R) is not the correct explanation of Assertion (A).
- (C) Assertion (A) is true, but Reason (R) is false.
- (D) Both Assertion (A) and Reason (R) are false.

[2025 • Set 55-6-1]

Q25. Out of the four options given, in which transition will the emitted photon have the maximum wavelength?

- (A) $n = 4$ to $n = 3$
- (B) $n = 3$ to $n = 2$
- (C) $n = 2$ to $n = 1$
- (D) $n = 3$ to $n = 1$

[2025 • Set 55-7-1]

Q26. The minimum energy required to free the electron from the ground state of the hydrogen atom is:

- (A) 3.4 eV
- (B) less than 3.4 eV
- (C) 13.6 eV
- (D) between 13.6 eV and 3.4 eV

[2025 • Set 55-7-3]

Q27. The transition of electron that gives rise to the formation of the second spectral line of the Balmer series in the spectrum of hydrogen atom corresponds to:

- (A) $n_f = 2$ and $n_i = 3$
- (B) $n_f = 3$ and $n_i = 4$
- (C) $n_f = 2$ and $n_i = 4$

(D) $n_f = 2$ and $n_i = \infty$

[2024 • Set 55-1-1]

Q28. An alpha particle approaches a gold nucleus in Geiger-Marsden experiment with kinetic energy K . It momentarily stops at a distance d from the nucleus and reverses its direction. Then d is proportional to:

- (A) $\frac{1}{\sqrt{K}}$
(B) \sqrt{K}
(C) $\frac{1}{K}$
(D) K

[2024 • Set 55-2-1]

Q29. Energy levels A, B and C of an atom correspond to increasing values of energy i.e. $E_A < E_B < E_C$. Let λ_1, λ_2 and λ_3 be the wavelengths of radiation corresponding to the transitions C to B, B to A and C to A, respectively. The correct relation between λ_1, λ_2 and λ_3 is:

- (A) $\lambda_1^2 + \lambda_2^2 = \lambda_3^2$
(B) $\frac{1}{\lambda_1} + \frac{1}{\lambda_2} = \frac{1}{\lambda_3}$
(C) $\lambda_1 + \lambda_2 + \lambda_3 = 0$
(D) $\lambda_1 + \lambda_2 = \lambda_3$

[2024 • Set 55-2-1]

Q30. An electron makes a transition from $n = 2$ level to $n = 1$ level in the Bohr model of a hydrogen atom. Its period of revolution:

- (A) increases by 87.5%
(B) decreases by 87.5%
(C) increases by 43.75%
(D) decreases by 43.75%

[2024 • Set 55-3-1]

Q31. A proton and an alpha particle having equal velocities approach a target nucleus. They come momentarily to rest and then reverse their directions. The ratio of the distance of closest approach of the proton to that of the alpha particle will be:

- (A) $\frac{1}{2}$
(B) 2
(C) $\frac{1}{4}$
(D) 4

[2024 • Set 55-3-1]

- Q32.** In Balmer series of hydrogen atom, as the wavelength of spectral lines decreases, they appear
- (A) equally spaced and equally intense.
 - (B) further apart and stronger in intensity.
 - (C) closer together and stronger in intensity.
 - (D) closer together and weaker in intensity.

[2024 • Set 55-4-1]

- Q33.** The radius (r_n) of n^{th} orbit in Bohr model of hydrogen atom varies with n as

- (A) $r_n \propto n$
- (B) $r_n \propto \frac{1}{n}$
- (C) $r_n \propto n^2$
- (D) $r_n \propto \frac{1}{n^2}$

[2024 • Set 55-4-1]

- Q34.** Assertion (A): An alpha particle is moving towards a gold nucleus. The impact parameter is maximum for the scattering angle of 180° . Reason (R): The impact parameter in an alpha particle scattering experiment does not depend upon the atomic number of the target nucleus.

- (A) Both Assertion (A) and Reason (R) are true and Reason (R) is correct explanation of Assertion (A).
- (B) Both Assertion (A) and Reason (R) are true and Reason (R) is not the correct explanation of Assertion (A).
- (C) Assertion (A) is true but Reason (R) is false.
- (D) Both Assertion (A) and Reason (R) are false.

[2024 • Set 55-5-1]

- Q35.** The energy of an electron in the ground state of hydrogen atom is -13.6 eV. The kinetic and potential energy of the electron in the first excited state will be:

- (A) -13.6 eV, 27.2 eV
- (B) -6.8 eV, 13.6 eV
- (C) 3.4 eV, -6.8 eV
- (D) 6.8 eV, -3.4 eV

[2024 • Set 55-5-1]

- Q36.** The radius of the n^{th} orbit in Bohr model of hydrogen atom is proportional to:

- (A) n
- (B) $\frac{1}{n}$
- (C) n^2
- (D) $\frac{1}{n^2}$

[2023 • Set 55-1-1]

Q37. Hydrogen atom initially in the ground state, absorbs a photon which excites it to $n = 5$ level. The wavelength of the photon is:

- (A) 975 nm
- (B) 740 nm
- (C) 523 nm
- (D) 95 nm

[2023 • Set 55-1-1]

Q38. The atomic number of an atom represents:

- (A) number of neutrons in nucleus.
- (B) total number of protons and electrons in the atom.
- (C) number of protons in nucleus.
- (D) total number of protons and neutrons in nucleus.

[2023 • Set 55-1-2]

Q39. A hydrogen atom makes a transition from $n = 5$ to $n = 1$ orbit. The wavelength of photon emitted is λ . The wavelength of photon emitted when it makes a transition from $n = 5$ to $n = 2$ orbit is

- (A) $\frac{3}{2}\lambda$
- (B) $\frac{16}{7}\lambda$
- (C) $\frac{24}{7}\lambda$
- (D) $\frac{32}{7}\lambda$

[2023 • Set 55-2-1]

Q40. Specify the transition of electron in the wavelength of the line in the Bohr model of hydrogen atom which gives rise to the spectral line of highest wavelength.

- (A) $n = 3$ to $n = 1$
- (B) $n = 3$ to $n = 2$
- (C) $n = 4$ to $n = 1$
- (D) $n = 4$ to $n = 2$

[2023 • Set 55-2-2]

Q41. The ratio of maximum frequency and minimum frequency of light emitted in Balmer series of hydrogen spectrum, in Bohr's model, is:

- (A) $\frac{9}{5}$
- (B) $\frac{5}{9}$

- (C) $\frac{16}{7}$
 (D) $\frac{7}{16}$

[2023 • Set 55-3-1]

Q42. The potential energy of an electron in the second excited state in hydrogen atom is:

- (A) -3.4 eV
 (B) -3.02 eV
 (C) -1.51 eV
 (D) -6.8 eV

[2023 • Set 55-4-1]

Q43. The ratio of the magnitude of magnetic moment to that of angular momentum, of an electron revolving around the nucleus in a hydrogen atom is:

- (A) Zero
 (B) 9.27×10^{-24} C/kg
 (C) 8.8×10^{10} C/kg
 (D) 6.6×10^{-12} C/kg

[2023 • Set 55-4-2]

Q44. The diagram shows four energy level of an electron in Bohr model of hydrogen atom. Identify the transition in which the emitted photon will have the highest energy.

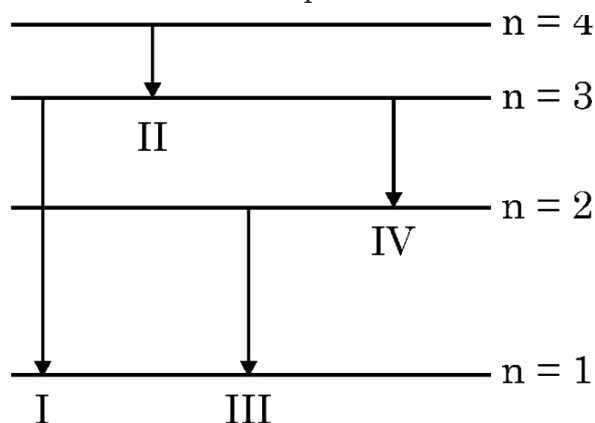

- (A) I
 (B) II
 (C) III
 (D) IV

[2023 • Set 55-5-1]

Q45. In Geiger-Marsden scattering experiment, thin gold foil is used to scatter alpha particles because alpha particles will (A) not suffer more than one scattering and gold nucleus is 50 times heavier than alpha particle. (B) not suffer more than one scattering and gold

nucleus is lighter than alpha particle. (C) not suffer more than few scatterings and gold nucleus is 25 times heavier than alpha particle. (D) suffer more than one scattering and gold nucleus is 25 times heavier than alpha particle.

[2021]

Q46. According to Bohr's atomic model, the circumference of the electron orbit is always an _____ multiple of de Broglie wavelength.

[2020 • Set 55-1-1]

Q47. Which of the following statements is not correct according to Rutherford model?

- (A) Most of the space inside an atom is empty.
- (B) The electrons revolve around the nucleus under the influence of coulomb force acting on them.
- (C) Most part of the mass of the atom and its positive charge are concentrated at its centre.
- (D) The stability of atom was established by the model.

[2020 • Set 55-1-1]

Q48. In Bohr's model of hydrogen atom, the total energy of the electron in n^{th} discrete orbit is proportional to

- (A) n
- (B) $\frac{1}{n}$
- (C) n^2
- (D) $\frac{1}{n^2}$

[2020 • Set 55-3-1]

Q49. In the α -particle scattering experiment, the shape of the trajectory of the scattered α -particles depend upon:

- (A) only on impact parameter.
- (B) only on the source of α -particles.
- (C) both impact parameter and source of α -particles.
- (D) impact parameter and the screen material of the detector.

[2020 • Set 55-4-1]

Q50. Paschen series of atomic spectrum of hydrogen gas lies in:

- (A) Infrared region
- (B) Ultraviolet region
- (C) Visible region
- (D) Partly in ultraviolet and partly in visible region

[2020 • Set 55-4-1]

- Q51. Define ionisation energy. What is its value for a hydrogen atom?
[2012]
- Q52. What is the ratio of radii of the orbits corresponding to first excited state and ground state in a hydrogen atom?
[2010]

2-Mark Questions (47 questions · Section B · VSA)

- Q1. Prove that, in Bohr model of hydrogen atom, the time period of revolution of an electron in n^{th} orbit is proportional to n^3 .
[2025 • Set 55-1-1]
- Q2. The energy of an electron in an orbit of Bohr hydrogen atom is -3.4 eV. Find its angular momentum.
[2025 • Set 55-1-2]
- Q3. An electron in Bohr model of hydrogen atom makes a transition from energy level -1.51 eV to -3.40 eV. Calculate the change in the radius of its orbit. The radius of orbit of electron in its ground state is 0.53 \AA .
[2025 • Set 55-1-3]
- Q4. Find the ratio of minimum to maximum wavelength of radiations emitted when electron jumps from higher energy state into ground state of hydrogen atom.
[2025 • Set 55-4-2]
- Q5. In Bohr's model of hydrogen atom, find the percentage change in the radius of its orbit when an electron makes a transition from $n = 3$ state to $n = 2$ state.
[2025 • Set 55-4-3]
- Q6. Define the term, 'distance of closest approach'. A proton of 3.95 MeV energy approaches a target nucleus $Z = 79$ in head-on position. Calculate its distance of closest approach.
[2025 • Set 55-5-3]
- Q7. An alpha particle and a deuterium ion are accelerated through the same potential difference. These are then directed towards a target nucleus to make head-on collision. It is observed that their distance of closest approach is the same. Justify it theoretically.
[2025 • Set 55-6-3]
- Q8. Define the 'distance of closest approach'. An α -particle of kinetic energy K is bombarded on a thin gold foil. Derive an expression for the 'distance of closest approach'.
[2025 • Set 55-7-3]

- Q9.** In Bohr model of hydrogen atom, find the ratio of period of revolution of the electron in the orbit $n = 2$ to that in the orbit $n = 1$.
[2024 • Set 55-2-3]
- Q10. (a)** Two energy levels of an electron in hydrogen atom are separated by 2.55 eV. Find the wavelength of radiation emitted when the electron makes transition from the higher energy level to the lower energy level.
(b) In which series of hydrogen spectrum this line shall fall?
[2024 • Set 55-5-1]
- Q11.** The earth revolves around the sun in an orbit of radius 1.5×10^{11} m with orbital speed 30 km/s. Find the quantum number that characterises its revolution using Bohr's model in this case (mass of earth = 6.0×10^{24} kg).
[2024 • Set 55-5-1]
- Q12.** A proton of energy 1.6 MeV approaches a gold nucleus ($Z = 79$). Find the distance of its closest approach.
[2024 • Set 55-5-2]
- Q13.** The electron in hydrogen atom is revolving with the speed of 2.2×10^6 m/s in an orbit of radius 0.53 \AA . Calculate the initial frequency of light emitted by the electron using classical physics.
[2024 • Set 55-5-3]
- Q14.** The ground state energy of hydrogen atom is -13.6 eV. What is the potential energy and kinetic energy of an electron in the third excited state?
[2023 • Set 55-1-1]
- Q15.** Calculate the wavelength of the second line of Lyman series in a spectrum of hydrogen atom. (Take Rydberg constant, $R = 1.1 \times 10^7 \text{ m}^{-1}$.)
[2023 • Set 55-1-2]
- Q16.** The ground state energy of hydrogen atom is -13.6 eV in Bohr model. An electron makes a transition from an energy level of -1.51 eV to that of -3.4 eV. Calculate the wavelength of the spectral line emitted.
[2023 • Set 55-1-3]
- Q17.** What is meant by ionisation energy? Write its value for hydrogen atom.
[2023 • Set 55-2-1]
- Q18.** Draw the graph showing the variation of the number (N) of scattered alpha particles with

scattering angle (θ) in Geiger-Marsden experiment. Infer two conclusions from the graph.

[2022 • Set 55-1-1]

Q19. (i) Define the terms: 'impact parameter' and 'distance of closest approach' for an α -particle in Geiger-Marsden scattering experiment.

(ii) What will be the value of the impact parameter for scattering angle (I) $\theta = 0^\circ$ and (II) $\theta = 180^\circ$?

[2022 • Set 55-2-1]

Q20. Name the spectral series for a hydrogen atom which lies in the visible region. Find the ratio of the maximum to the minimum wavelengths of this series.

[2022 • Set 55-4-1]

Q21. What results do you expect if α -particle scattering experiment is repeated using a thin sheet of hydrogen in place of a gold foil? Explain. (Hydrogen is a solid at temperature below 14 K)

[2022 • Set 55-5-1]

Q22. Using Bohr's atomic model, derive the expression for the radius of n^{th} orbit of the revolving electron in a hydrogen atom.

[2020 • Set 55-1-1]

Q23. Using Bohr's atomic model, derive the expression for the velocity of electron revolving in the n^{th} orbit of hydrogen atom.

[2020 • Set 55-1-3]

Q24. In Geiger-Marsden scattering experiment, the trajectory of α -particles in Coulomb's field of a heavy nucleus is shown in the figure.

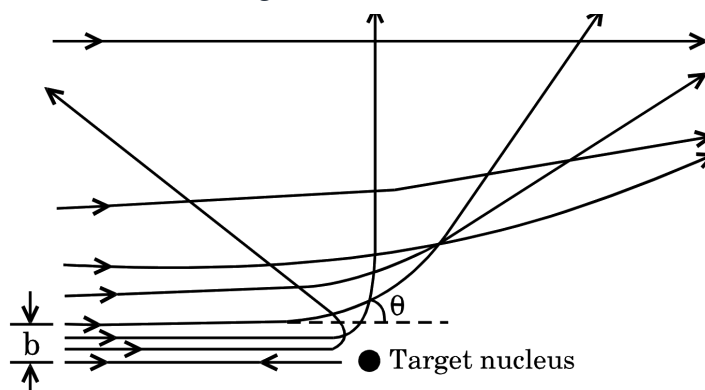

(a) What do 'b' and ' θ ' represent in the figure?

(b) What will be the value of 'b' for (i) $\theta = 0^\circ$, and (ii) $\theta = 180^\circ$?

[2020 • Set 55-2-1]

- Q25.** A hydrogen atom is in its third excited state.
- (a) How many spectral lines can be emitted by it before coming to the ground state? Show these transitions in the energy level diagram.
- (b) In which of the above transitions will the spectral line of shortest wavelength be emitted?
- [2020 • Set 55-3-1]
- Q26.** Use Bohr's model of hydrogen atom to obtain the relationship between the angular momentum and the magnetic moment of the revolving electron.
- [2020 • Set 55-5-1]
- Q27.** Write shortcomings of Rutherford atomic model. Explain how these were overcome by the postulates of Bohr's atomic model.
- [2020 • Set 55-5-3]
- Q28.** State Bohr's quantization condition of angular momentum. Calculate the shortest wavelength of the Brackett series and state to which part of the electromagnetic spectrum does it belong.
- [2019 • Set 55-1-1]
- Q29.** Calculate the orbital period of the electron in the first excited state of hydrogen atom.
- [2019 • Set 55-1-1]
- Q30.** Obtain the expression for the ratio of the de-Broglie wavelengths associated with the electron orbiting in the second and third excited states of hydrogen atom.
- [2019 • Set 55-1-3]
- Q31.** A photon emitted during the de-excitation of electron from a state n to the first excited state in a hydrogen atom, irradiates a metallic cathode of work function 2 eV, in a photo cell, with a stopping potential of 0.55 V. Obtain the value of the quantum number of the state n .

————— OR —————

A hydrogen atom in the ground state is excited by an electron beam of 12.5 eV energy. Find out the maximum number of lines emitted by the atom from its excited state.

[2019 • Set 55-2-1]

- Q32.** Obtain Bohr's quantisation condition for angular momentum of electron orbiting in n^{th} orbit in hydrogen atom on the basis of the wave picture of an electron using de Broglie hypothesis.

[2019 • Set 55-3-1]

Q33. An electron in a hydrogen atom in the second excited state jumps to the first and ground state of the atom. Find the ratio of the wavelengths emitted during this process.

[2019 • Set 55-3-2]

Q34. Define the distance of closest approach. An α -particle of kinetic energy ' K ' is bombarded on a thin gold foil. The distance of the closest approach is ' r '. What will be the distance of closest approach for an α -particle of double the kinetic energy?

————— OR —————

Write two important limitations of Rutherford nuclear model of the atom.

[2017]

Q35. Find out the wavelength of the electron orbiting in the ground state of hydrogen atom.

[2017]

Q36. A 12.5 eV electron beam is used to excite a gaseous hydrogen atom at room temperature. Determine the wavelengths and the corresponding series of the lines emitted.

[2017]

Q37. The short wavelength limit for the Lyman series of the hydrogen spectrum is 913.4 Å. Calculate the short wavelength limit for Balmer series of the hydrogen spectrum.

[2017]

Q38. The ground state energy of hydrogen atom is -13.6 eV. If an electron makes a transition from an energy level -1.51 eV to -3.4 eV, calculate the wavelength of the spectral line emitted and name the series of hydrogen spectrum to which it belongs.

[2017]

Q39. Define ionization energy. How would the ionization energy change when electron in hydrogen atom is replaced by a particle of mass 200 times that of the electron but having the same charge?

————— OR —————

Calculate the shortest wavelength of the spectral lines emitted in Balmer series. [Given Rydberg constant, $R = 10^7 \text{ m}^{-1}$]

[2016]

Q40. Show mathematically how Bohr's postulate of quantization of orbital angular momentum in hydrogen atom is explained by de-Broglie's hypothesis.

[2016]

Q41. A hydrogen atom initially in its ground state absorbs a photon and is in the excited

state with energy 12.5 eV. Calculate the longest wavelength of the radiation emitted and identify the series to which it belongs. [Take Rydberg constant $R = 1.1 \times 10^7 \text{ m}^{-1}$]

————— OR —————

Use Bohr model of hydrogen atom to calculate the speed of the electron in the first excited state.

[2016]

Q42. When is H_α line in the emission spectrum of hydrogen atom obtained? Calculate the frequency of the photon emitted during this transition.

[2016]

Q43. Calculate the wavelength of radiation emitted when electron in a hydrogen atom jumps from $n = \infty$ to $n = 1$.

[2016]

Q44. In the ground state of hydrogen atom, its Bohr radius is given as $5.3 \times 10^{-11} \text{ m}$. The atom is excited such that the radius becomes $21.2 \times 10^{-11} \text{ m}$. Find (i) the value of the principal quantum number and (ii) the total energy of the atom in this excited state.

————— OR —————

The energy levels of a hypothetical atom are shown below. Which of the shown transitions will result in the emission of photon of wavelength 275 nm?

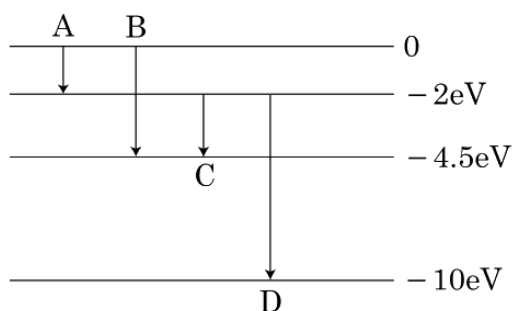

[2016]

Q45. How does one explain, using de Broglie hypothesis, Bohr's second postulate of quantization of orbital angular momentum?

[2015]

Q46. Show that the radius of the orbit in hydrogen atom varies as n^2 , where n is the principal quantum number of the atom.

[2015]

Q47. Using Rutherford model of the atom, derive the expression for the total energy of the electron in hydrogen atom. What is the significance of total negative energy possessed by the electron ?

— OR —

Using Bohr's postulates of the atomic model, derive the expression for radius of n^{th} electron orbit. Hence obtain the expression for Bohr's radius.

[2014]

3-Mark Questions (64 questions · Section C · SA)

Q1. (a) State Bohr's second postulate and mention its significance.

(b) Prove that, in Bohr model of hydrogen atom as principal quantum number n becomes large, the energy levels get closer and closer.

[2026 · Set 55-2-1]

Q2. Calculate the de Broglie wavelength associated with an electron revolving in the second excited state of hydrogen atom. The ground state energy of the hydrogen atom is -13.6 eV. Take $m_e = 9 \times 10^{-31}$ kg, $h = 6.6 \times 10^{-34}$ J s.

[2026 · Set 55-2-2]

Q3. A deuterium nucleus and an alpha particle approach a target nucleus separately in head-on position. Find the ratio of their distance of closest approach to the nucleus, when both have:

(a) the same velocity, and

(b) the same momentum.

[2026 · Set 55-3-3]

Q4. In Bohr model of hydrogen atom, calculate:

(a) the radius of the innermost electron orbit, and

(b) the speed of electron in this orbit.

[2026 · Set 55-4-2]

Q5. (b) (i) Draw the number of scattered particles versus the scattering angle graph for scattering of alpha particles by a thin foil. Write two important conclusions that can be drawn from this plot. **(ii)** If Bohr's quantization postulate (angular momentum $= \frac{nh}{2\pi}$) is a basic law of nature, it should be equally valid for the case of planetary motion also. Why, then, do we never speak of quantization of orbits

of planets around the Sun? Explain.

[2026 • Set 55-5-1]

Q6. How is the necessary force provided to an electron to keep it moving in a circular orbit according to Bohr model of hydrogen atom? Derive an expression for the total energy of an electron moving in an orbit of radius r in hydrogen atom. Give the significance of negative sign in this expression.

[2025 • Set 55-6-1]

Q7. Describe briefly Geiger-Marsden scattering experiment. Depict the graph showing the variation of number of scattered particles detected with the scattering angle. How did this graph lead to the discovery of the nucleus?

[2025 • Set 55-6-2]

Q8. In Bohr model of hydrogen atom, an electron is revolving in second orbit. Find the value of:

- (i) angular momentum of electron,
- (ii) radius of the orbit, and
- (iii) kinetic energy of electron. Take radius of first orbit of hydrogen atom as 0.5 \AA .

[2025 • Set 55-6-3]

Q9. Write the mathematical forms of three postulates of Bohr's theory of the hydrogen atom. Using them prove that, for an electron revolving in the n^{th} orbit,

- (a) the radius of the orbit is proportional to n^2 , and
- (b) the total energy of the atom is proportional to $\left(-\frac{1}{n^2}\right)$.

[2025 • Set 55-7-1]

Q10. Write the drawbacks of Rutherford's atomic model. How did Bohr remove them? Show that different orbits in Bohr's atom are not equally spaced.

[2024 • Set 55-1-1]

Q11. State the three postulates of Bohr's theory of hydrogen atom. A hydrogen atom de-excites from level n to level $(n - 1)$. Show that, according to Bohr's theory, the frequency of radiation emitted $\nu = \frac{C}{n^3}$ for large values of n , where C is a constant. This result exactly agrees with that obtained from classical physics — one of the successes of Bohr's theory.

[2024 • Set 55-1-3]

Q12. Using Bohr's postulates, derive the expression for the radius of the n^{th} orbit of an electron

in a hydrogen atom. Also find the numerical value of Bohr's radius a_0 .

[2024 • Set 55-2-1]

Q13. Draw a schematic arrangement of Geiger-Marsden experiment. Briefly explain the conclusions drawn from the observations about the structure of an atom. Define 'distance of closest approach' in this case.

[2024 • Set 55-2-3]

Q14. State Bohr's first and second postulates. Use them to derive an expression for the radius of the n th orbit in a hydrogen atom.

[2024 • Set 55-3-1]

Q15. Explain the origin of the spectral lines of hydrogen atom using Bohr's theory. Draw the energy level diagram of hydrogen atom showing its various spectral series.

[2024 • Set 55-3-2]

Q16. State Bohr's second postulate for his theory of hydrogen atom. Prove that the radius of Bohr's orbit of a hydrogen atom is directly proportional to n^2 , where n is the principal quantum number.

[2024 • Set 55-3-3]

Q17. Draw the graph showing variation of scattered particles detected (N) with the scattering angle (θ) in Geiger-Marsden experiment. Write two conclusions that you can draw from this graph. Obtain the expression for the distance of closest approach in this experiment.

[2024 • Set 55-4-1]

Q18. Draw the energy level diagram for hydrogen atom. Mark the transitions corresponding to the series lying in the ultraviolet region, visible region and infrared region.

[2023 • Set 55-1-1]

Q19. Briefly explain Geiger-Marsden experiment. Show the variation of the number of particles scattered (N) with scattering angle (θ) in this experiment. What is the main conclusion that can be inferred from this plot?

[2023 • Set 55-4-1]

Q20. (a) Differentiate between 'impact parameter' and 'distance of closest approach' in alpha particle scattering experiment. Identify, situations when impact parameter is (i) minimum, and (ii) very large.

(b) An electron cannot revolve around the nucleus in a hydrogen atom at an arbitrary distance. Explain.

[2023 • Set 55-4-2]

- Q21. (a) (i)** Differentiate between 'distance of closest approach' and 'impact parameter'. **(ii)** Determine the distance of closest approach when an alpha particle of kinetic energy 3.95 MeV approaches a nucleus of $Z = 79$, stops and reverses its directions.

— OR —

- (b) (i)** State three postulates of Bohr's theory of hydrogen atom. **(ii)** Find the angular momentum of an electron revolving in the second orbit in Bohr's hydrogen atom.

[2023 • Set 55-5-1]

- Q22. (a) (i)** Write the limitations of Rutherford's model of atom. **(ii)** The wavelength of the second line of the Balmer series in the hydrogen spectrum is 4861 . Calculate the wavelength of the first line of the same series.

— OR —

- (b) (i)** Increase in the intensity of the radiation causing photo-electric emission from a surface, does not affect the maximum K.E. of the photo electrons. Explain. **(ii)** The photon emitted during the de-excitation from the first excited level to the ground state of hydrogen atom is used to irradiate a photo cathode in which stopping potential is 5 V. Calculate the work function of the cathode used.

[2023 • Set 55-5-2]

- Q23.** Define the term — Distance of closest approach. How will it be affected, for an α -particle, if kinetic energy of the particle is doubled?

[2022 • Set 55-1-1]

- Q24. (a)** Sketch the energy level diagram for hydrogen atom.

- (b)** Find the ratio of the longest and the shortest wavelength in Lyman series in hydrogen atom.

[2022 • Set 55-1-2]

- Q25.** The energy of a hydrogen atom in the first excited state is -3.4 eV. Find:

- (a)** the radius of this orbit. (Take Bohr radius = 0.53 \AA)
(b) the angular momentum of the electron in the orbit.
(c) the kinetic and potential energy of the electron in the orbit.

[2022 • Set 55-2-1]

- Q26. (i)** State Bohr's quantization condition for defining stationary orbits.

- (ii)** Use the energy level diagram shown below to obtain the relation between three wavelengths λ_1 , λ_2 and λ_3 emitted due to the transition of electron from the energy

states C and B .

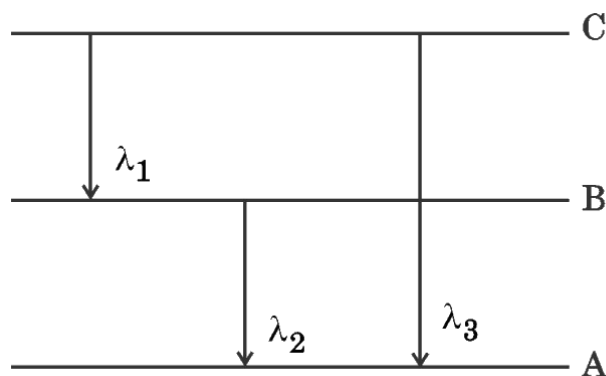

[2022 • Set 55-2-2]

Q27. An electron is in the third excited state in a hydrogen atom. It undergoes transitions to the lower energy states.

- What is the maximum number of spectral lines that can be emitted?
- Calculate the minimum wavelength of the spectral lines emitted.

[2022 • Set 55-2-3]

Q28. State Bohr's postulate to explain stable orbits in a hydrogen atom. Prove that the speed with which the electron revolves in n^{th} orbit is proportional to $(1/n)$.

[2022 • Set 55-3-1]

Q29. A narrow beam of protons, each having 4.1 MeV energy is approaching a sheet of lead ($Z = 82$). Calculate:

- the speed of a proton in the beam, and
- the distance of its closest approach.

[2022 • Set 55-3-1]

Q30. (a) The energy of hydrogen atom in an orbit is -1.51 eV. What are kinetic and potential energies of the electron in this orbit?

- The electron in a hydrogen atom is typically found at a distance of about 5.3×10^{-11} m from the nucleus which has a diameter of about 1.0×10^{-15} m. Assuming the hydrogen atom to be a sphere of radius 5.3×10^{-11} m, what fraction of its volume is occupied by the nucleus?

[2022 • Set 55-3-3]

Q31. (a) In Geiger-Marsden experiment, calculate the distance of closest approach for an alpha particle with energy 2.56×10^{-12} J. Consider that the particle approaches the gold nucleus ($Z = 79$) in head-on position.

(b) If the above experiment is repeated with a proton of the same energy, then what will be the value of the distance of closest approach?

[2022 • Set 55-4-1]

Q32. Draw a graph showing the variation of number of particles scattered (N) with the scattering angle θ in Geiger-Marsden experiment. Why only a small fraction of the particles are scattered at $\theta > 90^\circ$? Mention two limitations of Rutherford nuclear model of an atom.

[2022 • Set 55-5-1]

Q33. (a) Use Bohr's postulate to prove that the radius of n^{th} orbit in a hydrogen atom is proportional to n^2 .

(b) How will the energy of a hydrogen atom change if n increases from 1 to 2?

[2022 • Set 55-5-2]

Q34. An electron in a hydrogen atom makes transitions from orbits of higher energies to orbits of lower energies.

(i) When will such transitions result in (a) Lyman (b) Balmer series?

(ii) Find the ratio of the longest wavelength in Lyman series to the shortest wavelength in Balmer series.

[2022 • Set 55-5-3]

Q35. In a Geiger-Marsden experiment, find the distance of closest approach to the gold nucleus (mass no. = 79) of a 7.7 MeV α -particle before it comes momentarily to rest and reverses its direction. Why is it different from actual radius of gold nucleus? Plot a graph between number of scattered α -particles detected in gold foil experiment and angle of scattering. What is the main assumption in plotting this graph?

[2021]

Q36. (a) Draw the graph of radius of orbit (r_n) in hydrogen atom as a function of orbit number (n).

(b) In a hydrogen atom, find the ratio of the time taken by the electron to complete one revolution in the first excited and in the second excited states.

[2020 • Set 55-2-3]

Q37. Calculate the de-Broglie wavelength associated with the electron revolving in the first excited state of hydrogen atom. The ground state energy of the hydrogen atom is -13.6 eV.

[2020 • Set 55-5-1]

Q38. Explain briefly how Rutherford scattering of α -particle by a target nucleus can provide information on the size of the nucleus.

[2019 • Set 55-1-3]

Q39. Prove that the magnetic moment of the electron revolving around a nucleus in an orbit of radius r with orbital speed v is equal to $evr/2$. Hence using Bohr's postulate of quantization of angular momentum, deduce the expression for the magnetic moment of hydrogen atom in the ground state.

[2019 • Set 55-2-1]

Q40. Draw a plot of α -particle scattering by a thin foil of gold to show the variation of the number of the scattered particles with scattering angle. Describe briefly how the large angle scattering explains the existence of the nucleus inside the atom. Explain with the help of impact parameter picture, how Rutherford scattering serves a powerful way to determine an upper limit on the size of the nucleus.

[2019 • Set 55-2-1]

Q41. (a) How is the stability of hydrogen atom in Bohr model explained by de-Broglie's hypothesis?

(b) A hydrogen atom initially in the ground state absorbs a photon which excites it to $n = 4$ level. When it gets de-excited, find the maximum number of lines which are emitted by the atom. Identify the series to which these lines belong. Which of them has the shortest wavelength?

[2019 • Set 55-2-2]

Q42. (a) Draw the energy level diagram for the line spectra representing Lyman series and Balmer series in the spectrum of hydrogen atom.

(b) Using the Rydberg formula for the spectrum of hydrogen atom, calculate the largest and shortest wavelengths of the emission lines of the Balmer series in the spectrum of hydrogen atom. (Use the value of Rydberg constant $R = 1.1 \times 10^7 \text{ m}^{-1}$)

[2019 • Set 55-2-3]

Q43. (a) Using Bohr's postulates, derive the expression for the orbital period of the electron moving in the n^{th} orbit of hydrogen atom.

(b) Write Rydberg's formula for wavelengths of the spectral lines of hydrogen atom spectrum. Mention to which series in the emission spectrum of hydrogen, H_β line belongs.

[2019 • Set 55-4-1]

Q44. Using Bohr's postulates, derive the expression for the radius of the n^{th} orbit in which the electron is revolving in hydrogen atom. How does de-Broglie's hypothesis explain the

stability of hydrogen atom? Explain.

[2019 • Set 55-4-2]

Q45. Use Bohr's postulates to derive the expressions for the potential and kinetic energy of the electron moving in the n^{th} orbit of the hydrogen atom. How is the total energy of the electron expressed in terms of its kinetic and potential energies?

[2019 • Set 55-4-3]

Q46. Obtain the first Bohr's radius and the ground state energy of a muonic hydrogen atom i.e. an atom where the electron is replaced by a negatively charged muon (μ^-) of mass about $207 m_e$ that orbits around a proton. (Given for hydrogen atom, radius of first orbit and ground state energy are 0.53×10^{-10} m and -13.6 eV respectively)

[2019 • Set 55-5-1]

Q47. A hydrogen atom in its excited state emits radiations of wavelengths 1218 \AA and 974.3 \AA when it finally comes to the ground state. Identify the energy levels from where transitions occur. Given Rydberg constant $R = 1.1 \times 10^7 \text{ m}^{-1}$. Also specify the spectral series to which these lines belong.

[2019 • Set 55-5-2]

Q48. Hydrogen atom in third excited state de-excites to the first excited state. Obtain the expressions for the frequency of radiation emitted in this process. Also determine the ratio of the wavelengths of the emitted radiations when the atom de-excites from the third excited state to the second excited state and from the third excited state to the first excited state.

[2019 • Set 55-5-3]

Q49. (a) State Bohr's postulate to define stable orbits in hydrogen atom. How does de Broglie's hypothesis explain the stability of these orbits ?

(b) A hydrogen atom initially in the ground state absorbs a photon which excites it to the $n = 4$ level. Estimate the frequency of the photon.

[2018]

Q50. Using Bohr's postulates, derive the expression for the orbital period of the electron moving in the n^{th} orbit of hydrogen atom.

[2017]

Q51. In the study of Geiger-Marsden experiment on scattering of α particles by a thin foil of gold, draw the trajectory of α -particles in the coulomb field of target nucleus. Explain briefly how one gets the information on the size of the nucleus from this study. From the relation $R = R_0 A^{1/3}$, where R_0 is constant and A is the mass number of the nucleus,

show that nuclear matter density is independent of A .

[2015]

Q52. A 12.5 eV electron beam is used to bombard gaseous hydrogen at room temperature. Upto which energy level the hydrogen atoms would be excited ? Calculate the wavelengths of the first member of Lyman and first member of Balmer series.

[2014]

Q53. A 12.9 eV beam of electrons is used to bombard gaseous hydrogen at room temperature. Upto which energy level the hydrogen atoms would be excited ? Calculate the wavelength of the first member of Paschen series and first member of Balmer series.

[2014]

Q54. Using Bohr's postulates, obtain the expression for the total energy of the electron in the stationary states of the hydrogen atom. Hence draw the energy level diagram showing how the line spectra corresponding to Balmer series occur due to transition between energy levels.

[2013]

Q55. In a Geiger-Marsden experiment, calculate the distance of closest approach to the nucleus of $Z = 80$, when an α -particle of 8 MeV energy impinges on it before it comes momentarily to rest and reverses its direction. How will the distance of closest approach be affected when the kinetic energy of the α -particle is doubled?

————— OR —————

The ground state energy of hydrogen atom is -13.6 eV. If an electron makes a transition from an energy level -0.85 eV to -3.4 eV, calculate the wavelength of the spectral line emitted. To which series of hydrogen spectrum does this wavelength belong?

[2012]

Q56. (a) Using Bohr's second postulate of quantization of orbital angular momentum show that the circumference of the electron in the n^{th} orbital state in hydrogen atom is n times the de Broglie wavelength associated with it.

(b) The electron in hydrogen atom is initially in the third excited state. What is the maximum number of spectral lines which can be emitted when it finally moves to the ground state?

[2012]

Q57. Using Bohr's postulates for hydrogen atom, show that the total energy (E) of the electron in the stationary states can be expressed as the sum of kinetic energy (K) and potential energy (U), where $K = -2U$. Hence deduce the expression for the total energy in the n^{th}

energy level of hydrogen atom.

[2012]

Q58. (a) Using de Broglie's hypothesis, explain with the help of a suitable diagram, Bohr's second postulate of quantization of energy levels in a hydrogen atom.

(b) The ground state energy of hydrogen atom is -13.6 eV. What are the kinetic and potential energies of the electron in this state?

[2011]

Q59. The energy levels of a hypothetical atom are shown below. Which of the shown transitions will result in the emission of a photon of wavelength 275 nm? Which of these transitions correspond to emission of radiation of (i) maximum and (ii) minimum wavelength?

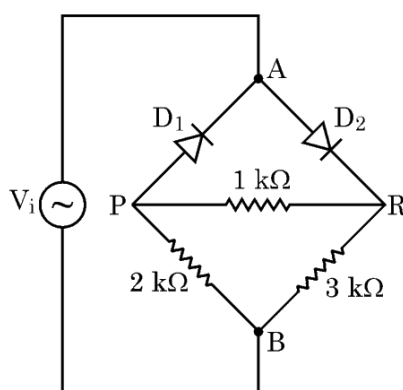

[2011 • Set 55-1-1]

Q60. Using the postulates of Bohr's model of hydrogen atom, obtain an expression for the frequency of radiation emitted when the atom makes a transition from the higher energy state with quantum number n_i to the lower energy state with quantum number n_f ($n_f < n_i$).

[2011 • Set 55-2-1]

Q61. (a) The energy levels of an atom are as shown below. Which of them will result in the transition of a photon of wavelength 275 nm?

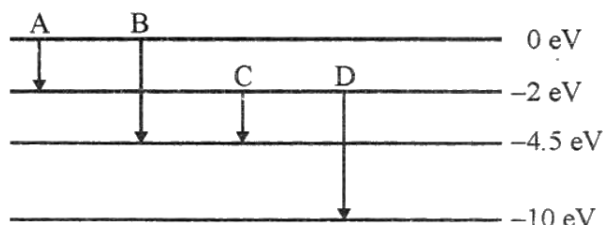

(b) Which transition corresponds to emission of radiation of maximum wavelength?

[2009]

Q62. Draw a schematic arrangement of the Geiger-Marsden experiment. How did the scattering of α -particles by a thin foil of gold provide an important way to determine an upper limit on the size of the nucleus? Explain briefly.

[2009]

Q63. The energy level diagram of an element is given below. Identify, by doing necessary calculations, which transition corresponds to emission of a spectral line of wavelength 102.7 nm .

[2008]

Q64. Show that Bohr's second postulate, 'the electron revolves around the nucleus only in certain fixed orbits without radiating energy' can be explained on the basis of de Broglie hypothesis of wave nature of electron.

[2008]